





APPENDIX A
Essex Coastal Scenic Byway Region





 Essex Coastal Scenic Byway

 Interstate

 U.S. Highway

 State Route



 Miles
0 1 2 3 4

Map created by Brown Walker Planners, Inc.
Source: MassGIS

APPENDIX B

List of Participants

Study Advisory Meetings

April 4, 2013

May 22, 2013

February 10, 2014

Bicycle Tour:

Reconnaissance of Roadway Conditions

May 3, 2013

List of Participants at Study Advisory Meetings
Subregional Priority Roadways Study: Routes 127A/127 in Gloucester and Rockport

Name	Affiliation	Email Address	4/4/13	5/3/13	5/22/13	2/10/14
Tom Daniel	Gloucester Community Development	tdaniel@gloucester-ma.gov	√			
Gregg Cademartori	Gloucester Community Development	gcademartori@gloucester-ma.gov	√	√		
Stephen Winslow	Gloucester Community Development	swinslow@gloucester-ma.gov	√	√	√	√
Joseph Parisi	Rockport Department of Public Works	jparisi@town.rockport.ma.us			√	√
Tim Olson	Rockport Department of Public Works	tolson@town.rockport.ma.us			√	√
John T. McCathy	Rockport Police Department	chief@rockportpd.org				√
Carolyn Britt	Rockport Planning	cbritt@communityinvestment.net			√	
Bill Steelman	Essex National Heritage Commission	bills@essexheritage.org	√	√		√
Barry Pett	State Senator Tarr's Office	barry.pett@masenate.gov				√
Jeff Cox	North Shore Cyclists	jeffrey.cox2@gmail.com	√			
Peter Webber	Cape Ann Chamber of Commerce	peter@capeannchamber.com	√			
Dana Menon	Salem Planning Department	dmenon@salem.com	√			
Michael Karas	MassDOT District 4 Traffic	MIKE.KARAS@DOT.STATE.MA.US	√			
Sam Cleaves	MAPC NSTF Coordinator	scleaves@MAPC.org	√	√		√
David Loutzenheiser	MAPC Bike/Ped. Transportation	dloutzenheiser@MAPC.org	√	√	√	√
Efi Pagitsas	CTPS Traffic Analysis & Design	epagitsas@ctps.org				√
Chen-Yuan Wang	CTPS Traffic Analysis & Design	cwang@ctps.org	√	√	√	√

APPENDIX C

Cape Ann Transportation Authority Bus Services in the Study Area



MBTA Newburyport /
Rockport Commuter
Rail Line from Beverly



MAP KEY:

- Ⓣ TRAIN CONNECTION
- DENOTES CATA STOPS
- || ZONE BOUNDARY

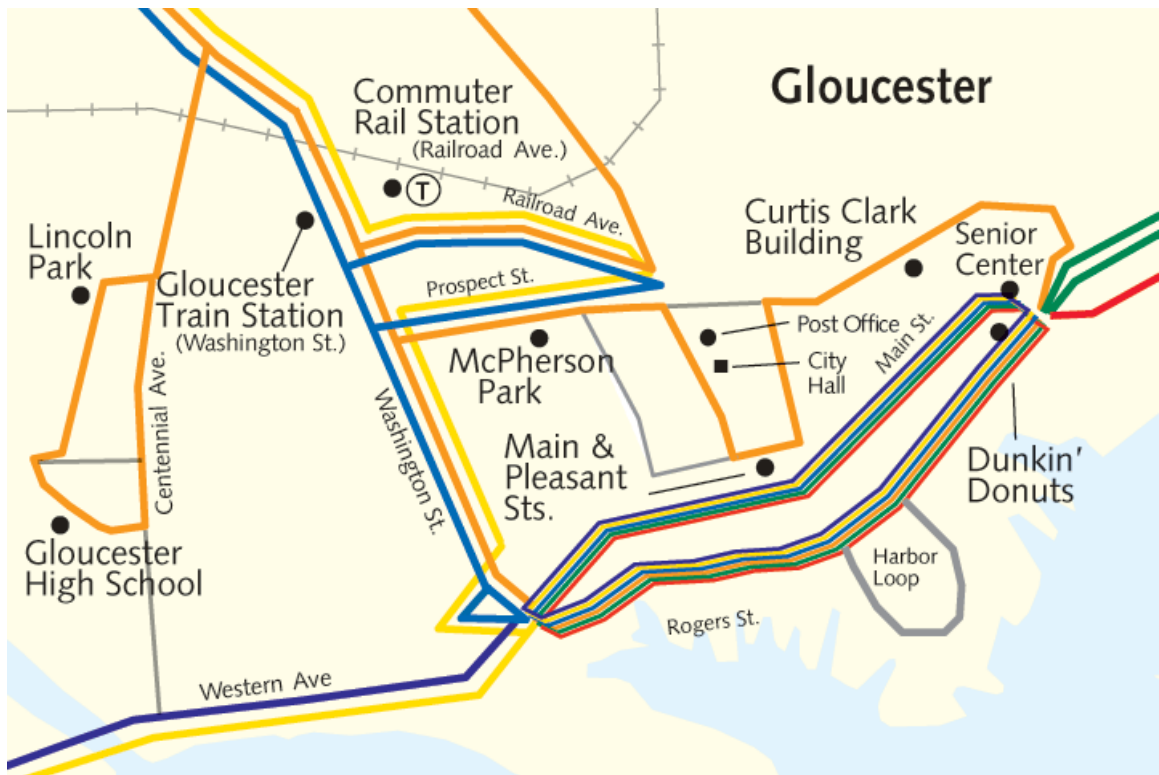



ANNUAL SCHEDULE

Cape Ann Transportation Authority

FARES zone	disabled Medicare children		
	regular	seniors*	5-12†

1: Gloucester	1.00	.50	1.00
2: Rockport	1.25	.60	1.25

West Gloucester (west of Route 128)
Magnolia (south of Western and Hesperus Avenues)

*A senior is anyone 60 or older.
Verification of age may be required.
†Children under five (5) ride free of charge.

Danvers and Peabody Malls:			
round-trip	5.00	2.50	2.00
one-way	3.00	1.50	1.00

STUDENT PASS OPTIONS

The Unlimited Pass: An annual or semester pass that allows the holder unlimited use of the CATA system at no additional cost per ride.

The Pass Plus: An annual pass that allows the holder to ride at a reduced fare of 50 cents per trip.

Note: Student passes are not valid for Danvers and Peabody Malls.

GENERAL INFORMATION

- For your safety, do not cross in front of the bus. Let the bus pass and look both ways before crossing street.
- No smoking, eating or drinking.
- No loud talking, noise or radios.
- Offensive behavior will not be tolerated. The offender will be subject to ejection from the bus.
- Pay or show pass upon boarding - exact change is required.
- Appropriate dress, shirt and shoes required
- No rollerblades.
- Only caged or service animals allowed.

WAVE-A-BUS

Anywhere along the route, as well as at designated bus stops, passengers wishing to board the bus may wave to the driver, and the driver will stop at the first safe location. Passengers must stand on the same side of the road as the bus. During school pick-up and drop-off, Wave-A-Bus is not in effect.

HOLIDAYS

No bus service on Sundays or the following
New Year's Day • Martin Luther King Day
Presidents Day • Patriots Day
Memorial Day • July 4th • Labor Day
Columbus Day • Veterans Day
Thanksgiving • Christmas Day

SNOW EMERGENCIES

Reports of bus service interruption due to weather or other emergencies will be broadcast on WBOQ 104.9 FM.

PARATRANSIT SERVICE

Special transportation services are available for elderly and disabled persons. For more information call CATA.

CATA INFORMATION

978 283 7278 · www.canntan.com

NON DISCRIMINATION

CATA is committed to operating its transit services without regard to race, color and national origin. For further information contact CATA Administrator, 3 Pond Road, Rear, Gloucester, Mass., 978 283 1886.

Round-trip service from
downtown Gloucester except ■

Rockport via East Gloucester ·
Rocky Neck · Back Shore

Rockport via Eastern Avenue
Blackburn Industrial Park

Gloucester Crossing &
Business Express
Cruiseport Trolley

Rockport via Lanesville

Magnolia
Danvers & Peabody Malls
■ Beverly Shuttle

West Gloucester

CATA System · Gloucester ·
Rockport · MBTA maps
Español · Italiano · Português

Maps · Glossary

Key to Maps

Service to and from Rockport; West Gloucester (west of Route 128); and Magnolia (south of Western and Hesperus Avenues), is an additional zone.

To show service more clearly, geography is modified.

Key to Timetables

Gray columns are shown for readability.

Times in bus-line color indicate service that operates on school days only.

Times in bus-line color shaded columns indicate service that operates on non-school days only.

Transfers

For Travel in one direction, no additional fare is required for transfers from the Red, Red/Blue, Blue, Yellow or Purple lines to lines of another color except the Orange line. No free transfers are allowed from the Orange line (Gloucester Crossing & Business Express) to lines of another color.

For MBTA commuter rail station connections, see schedule below for Rockport, Gloucester, and West Gloucester departures and arrivals (for Beverly, see yellow line, Beverly Shuttle; for Ipswich, see purple line, Ipswich · Essex).

Schedule is effective November 20, 2010. For holiday service consult MBTA printed schedule, or (and for any changes) go to:

http://mbta.com/schedules_and_maps/rail/lines/

MBTA: 800 392 6100 or 617 222 3200

<http://www.mbta.com/>

MBTA Newburyport / Rockport Commuter Rail Line

INBOUND ROCKPORT · NORTH STATION / BOSTON

	MONDAY THROUGH FRIDAY												
Rockport	5 05	6 05	6 44	7 25	9 07	10 00	12 00	2 00	4 00	5 25	6 45	7 50	10 45
Gloucester	5 13	6 13	6 52	7 33	9 15	10 08	12 08	2 08	4 08	5 33	6 53	7 58	10 53
West Glou.	5 18	6 18	6 57	7 38	9 20	10 13	12 13	2 13	4 13	5 38	—	8 03	10 58

	SATURDAY & SUNDAY												
Rockport	—	—	—	7 00	—	10 00	12 00	2 00	—	5 10	—	7 30	10 00
Gloucester	—	—	—	7 08	—	10 08	12 08	2 08	—	5 18	—	7 38	10 08
West Glou.	—	—	—	7 13	—	10 13	12 13	2 13	—	5 23	—	7 43	10 13

OUTBOUND NORTH STATION / BOSTON · ROCKPORT

	MONDAY THROUGH FRIDAY												
West Glou.	8 36	9 30	11 14	1 14	3 16	4 59	5 52	6 20	7 09	7 57	9 24	11 36	1 02
Gloucester*	8 41	9 35	11 19	1 19	3 21	5 04	5 57	6 25	7 14	8 02	9 29	11 41	1 07
Rockport	8 51	9 43	11 27	1 27	3 29	5 12	6 06	6 35	7 22	8 10	9 37	11 49	1 16

	SATURDAY & SUNDAY												
West Glou.	—	9 25	11 12	1 10	3 08	—	—	6 25	—	—	9 23	12 22	—
Gloucester	—	9 30	11 17	1 15	3 13	—	—	6 30	—	—	9 28	12 27	—
Rockport	—	9 40	11 27	1 25	3 22	—	—	6 39	—	—	9 37	12 36	—

*Trains may leave ahead of schedule.

**ROCKPORT · GLOUCESTER · GHS /
GHS · GLOUCESTER · ROCKPORT**

AM	SCHOOL SERVICE		PM
—	—	Dock Square	2 58
—	—	South Street & Jerdens Lane	2 55
—	—	South Street & Eden Road	2 53
—	—	Cape Hedge Inn	2 51
—	—	South & Frank Streets	2 50
6 49	—	Long Beach Dairy Maid	2 47
6 50	—	Thatcher Road & Witham Street	2 46
6 50	—	Good Harbor Beach	—
—	—	Thatcher Road & Marina Drive	2 45
6 53	—	Atlantic & Beach Roads	2 37
6 55	—	Beach & Moorland Roads	—
6 56	—	Atlantic & Moorland Roads	2 34
6 57	—	Atlantic & High Popples Roads	2 33
6 58	—	Atlantic & Grapevine Roads	2 32
7 01	—	Niles Beach	2 29
7 02	—	Eastern Point & Grapevine Roads	2 28
7 03	7 03	East Main St. & Rocky Neck Avenue	2 27 2 38 3 06
7 05	7 05	East Gloucester Square	2 25 2 36
—	7 06	East Main & Haskell Streets	—
—	—	Bass Avenue & East Main Street	2 22 2 33
—	—	Bass Avenue & Hartz Street	— 2 32
—	7 07	Sayward Street & Bass Avenue	—
—	7 08	Thatcher Road & Marina Drive	— 2 31
—	7 09	Thatcher Road & Barn Lane	— 2 30
—	—	Eastern Avenue & Barn Lane	— 2 29
—	—	Eastern Avenue & Hartz Street	— 2 27
—	7 11	Eastern & Harrison Avenues	—
—	7 13	Eastern Avenue & Webster Street	— 2 26
—	—	depart Dunkin' Donuts® / Rogers St.	—
—	7 15	arrive Dunkin' Donuts / Rogers St.	2 20
7 10	—	Dunkin' Donuts	—
7 11	—	Main & Pleasant Streets	—
—	—	Prospect & Rogers Streets	— 2 23
7 15	—	Commuter Rail Station	—
7 20	7 20	GLOUCESTER HIGH SCHOOL	2 15 2 15 2 41

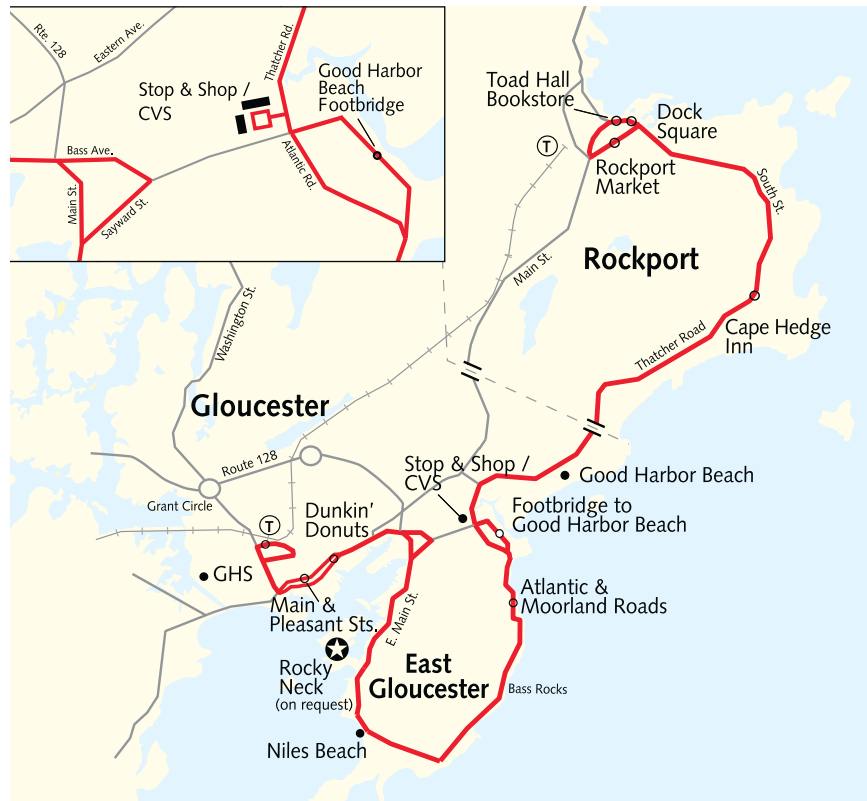

GLOUCESTER · ROCKPORT via Thatcher Road

MONDAY THROUGH FRIDAY							
Commuter Rail Station	—	—	—	—	—	5 57	6 22
arrive Dunkin' Donuts / Rogers St	—	—	—	—	2 45	—	—
depart Dunkin' Donuts / Rogers St	—	—	2 20	3 00	—	6 01	6 26
Dunkin' Donuts	8 25	—	12 25	—	—	4 20	—
Main & Pleasant Streets	8 26	—	12 26	—	—	4 21	—
E. Main St & Rocky Neck Ave	8 35	—	12 35	2 27	3 06	4 30	6 09 6 34
Niles Beach	8 37	—	12 37	2 29	—	4 32	6 11 6 36
Atlantic & Moorland Roads	8 40	—	12 40	2 34	—	4 35	— 6 39
Stop & Shop® / CVS®	8 43	—	12 43	2 43	—	4 38	—
Good Harbor Beach	8 45	—	12 45	2 45	—	4 40	—
Cape Hedge Inn	8 51	—	12 51	2 51	—	4 46	—
arrive Dock Square	8 56	—	12 56	2 58	—	4 51	—
depart Dock Square	9 00	—	1 00	3 00	—	4 51	—
Toad Hall Bookstore	9 01	—	1 01	3 01	—	4 52	—

SATURDAY							
Dunkin' Donuts	—	10 25	12 25	2 25	—	4 25	—
Main & Pleasant Streets	—	10 26	12 26	2 26	—	4 26	—
E. Main St. & Rocky Neck Ave.	—	10 35	12 35	2 35	—	4 35	—
Niles Beach	—	10 37	12 37	2 37	—	4 37	—
Atlantic & Moorland Roads	—	10 40	12 40	2 40	—	4 40	—
Stop & Shop / CVS	—	10 43	12 43	2 43	—	4 43	—
Good Harbor Beach	—	10 45	12 45	2 45	—	4 45	—
Cape Hedge Inn	—	10 51	12 51	2 51	—	4 51	—
arrive Dock Square	—	10 56	12 56	2 56	—	4 56	—
depart Dock Square	—	11 00	1 00	3 00	—	5 00	—
Toad Hall Bookstore	—	11 01	1 01	3 01	—	5 01	—

ROCKPORT · GLOUCESTER via Thatcher Road

MONDAY THROUGH FRIDAY							
Rockport Market	—	—	8 55	10 55	12 55	2 55	4 55
Cape Hedge Inn	—	—	9 00	11 00	1 00	3 00	5 00
Good Harbor Beach	—	6 50	9 06	11 06	1 06	3 06	5 06
Stop & Shop / CVS	—	—	9 08	11 08	1 08	3 08	5 08
Atlantic & Moorland Roads	6 16	6 55	9 11	11 11	1 11	3 11	5 11
Niles Beach	6 19	6 58	9 14	11 14	1 14	3 14	5 14
E. Main St & Rocky Neck Ave	6 21	7 00	9 16	11 16	1 16	3 16	5 16
arrive Dunkin' Donuts	6 29	7 08	9 24	11 24	1 24	3 24	5 24
depart Dunkin' Donuts	6 29	7 10	9 30	11 30	1 30	3 30	5 25
Main & Pleasant Streets	6 30	7 11	9 31	11 31	1 31	3 31	5 26
Commuter Rail Station	6 34	7 15	—	—	—	—	—
Addison Gilbert Hospital	6 37	—	—	—	—	—	—
Blackburn Industrial Park	6 42	—	—	—	—	—	—

SATURDAY							
Rockport Market	—	—	—	10 55	12 55	2 55	—
Cape Hedge Inn	—	—	—	11 00	1 00	3 00	—
Good Harbor Beach	—	—	—	11 06	1 06	3 06	—
Stop & Shop / CVS	—	—	—	11 08	1 08	3 08	—
Atlantic & Moorland Roads	—	—	—	11 11	1 11	3 11	—
Niles Beach	—	—	—	11 14	1 14	3 14	—
E. Main St & Rocky Neck Ave	—	—	—	11 16	1 16	3 16	—
arrive Dunkin' Donuts	—	—	—	11 24	1 24	3 24	—
depart Dunkin' Donuts	—	—	—	11 30	1 30	3 30	—
Main & Pleasant Streets	—	—	—	11 31	1 31	3 31	—

Rockport via East Gloucester · Rocky Neck · Back Shore

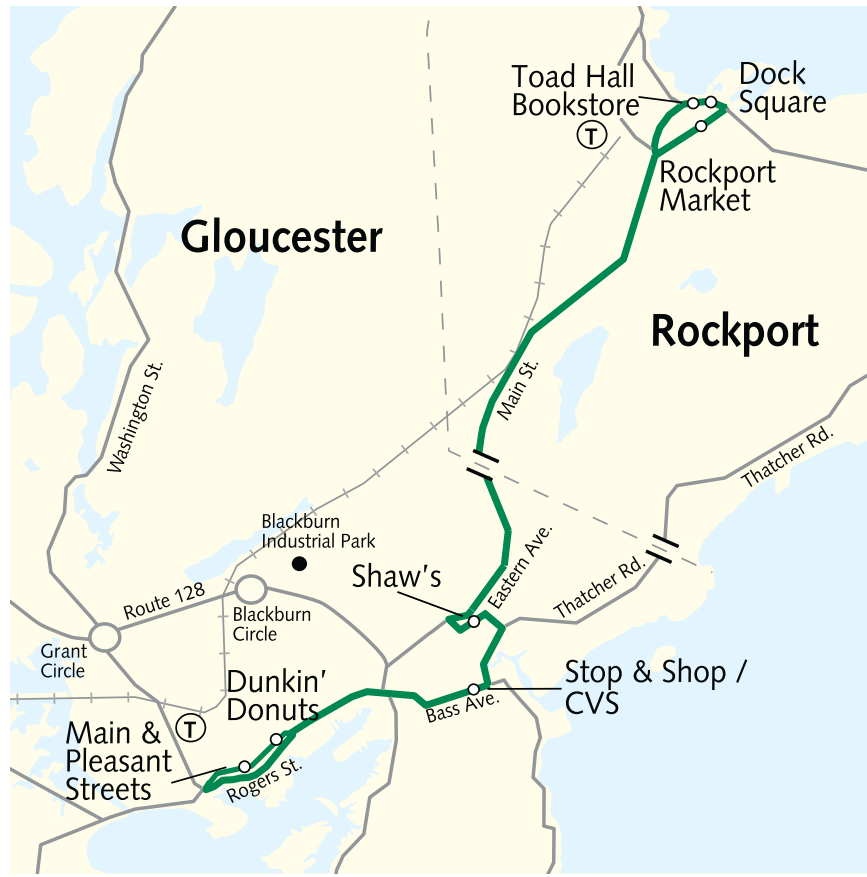

GLOUCESTER · ROCKPORT via Eastern Avenue

MONDAY THROUGH FRIDAY										
Dunkin' Donuts	7 30	8 30	9 30	10 30	11 30	12 30	1 30	—	—	5 20
Main & Pleasant Sts.	7 31	8 31	9 31	10 31	11 31	12 31	1 31	—	—	5 21
Stop & Shop / CVS	7 40	8 40	9 40	10 40	11 40	12 40	1 40	—	—	5 30
Shaw's Supermarket	7 41	8 41	9 41	10 41	11 41	12 41	1 41	—	—	5 31
arr Rockport Market	7 47	8 47	9 47	10 47	11 47	12 47	1 47	—	—	5 37
dp Rockport Market	7 50	8 55	9 50	10 55	11 50	12 55	1 50	—	—	5 40
Dock Sq/Toad Hall Bkst	7 51	—	9 51	—	11 51	—	1 51	—	—	5 41

SATURDAY										
Dunkin' Donuts	—	—	9 30	10 30	11 30	12 30	1 30	2 30	3 30	
Main & Pleasant Sts.	—	—	9 31	10 31	11 31	12 31	1 31	2 31	3 31	
Stop & Shop / CVS	—	—	9 40	10 40	11 40	12 40	1 40	2 40	3 40	
Shaw's Supermarket	—	—	9 41	10 41	11 41	12 41	1 41	2 41	3 41	
ar Rockport Market	—	—	9 47	10 47	11 47	12 47	1 47	2 47	3 47	
dp Rockport Market	—	—	9 55	10 55	11 55	12 55	1 55	2 55	3 55	
Dock Sq/Toad Hall Bkst	—	—	9 56	—	11 56	—	1 56	—	3 56	

ROCKPORT · GLOUCESTER via Eastern Avenue

MONDAY THROUGH FRIDAY										
Rockport Market	7 55	—	10 00	—	12 00	—	2 00	—	4 00	4 55 5 40
Dock Square	7 56	9 00	10 01	—	12 01	1 00	2 01	3 00	4 01	4 56 5 41
Toad Hall Bookstore	7 56	9 01	10 01	—	12 01	1 01	2 01	3 01	4 01	4 56 5 41
Commuter Rail Sta.	—	—	—	—	—	—	—	—	—	5 57
Shaw's Supermarket	8 04	9 09	10 09	—	12 09	1 09	2 09	3 09	4 09	5 04
Stop & Shop / CVS	8 05	9 10	10 10	—	12 10	1 10	2 10	3 10	4 10	5 05
Blackburn Ind. Park	—	—	—	—	—	—	—	—	—	5 11
arr Dunkin' Donuts	8 10	9 15	10 15	—	12 15	1 15	2 15	3 15	4 15	5 16
dep Dunkin' Donuts	8 10	9 25	10 25	—	12 25	1 20	2 20	3 20	4 20	5 20
Main & Pleasant Sts.	8 11	9 26	10 26	—	12 26	1 21	2 21	3 21	4 21	5 21

SATURDAY										
Rockport Market	—	—	10 00	—	12 00	—	2 00	—	4 00	—
Dock Square	—	—	10 01	11 00	12 01	1 00	2 01	3 00	4 01	5 00
Toad Hall Bookstore	—	—	10 01	11 01	12 01	1 01	2 01	3 01	4 01	5 01
Shaw's Supermarket	—	—	10 09	11 09	12 09	1 09	2 09	3 09	4 09	5 09
Stop & Shop / CVS	—	—	10 10	11 10	12 10	1 10	2 10	3 10	4 10	5 10
arr Dunkin' Donuts	—	—	10 15	11 15	12 15	1 15	2 15	3 15	4 15	5 15
dep Dunkin' Donuts	—	—	10 25	11 25	12 25	1 20	2 25	3 25	4 25	5 20
Main & Pleasant Sts.	—	—	10 26	11 26	12 26	1 21	2 26	3 26	4 26	5 21

Rockport Express via Eastern Avenue

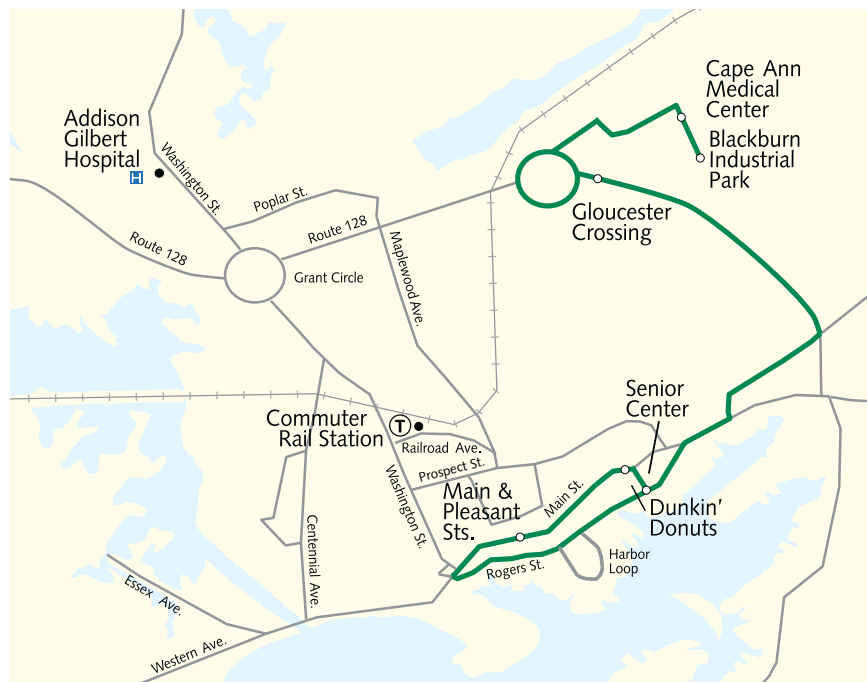

GLOUCESTER · Blackburn Industrial Park

MONDAY THROUGH FRIDAY

Dunkin' Donuts	6 29
Main & Pleasant Sts.	6 30
Commuter Rail Sta.	6 34
Addison Gilbert Hosp.	6 37
Blackburn Ind. Park	6 42

Additional service via Gloucester Crossing & Business Express,
on request, see below and/or orange-line timetable:

via Business Express · Blackburn Industrial Park

BLACKBURN ON REQUEST: MONDAY THROUGH FRIDAY

Dunkin' Donuts	—	8 00	9 00	10 00	11 00	12 00	1 00	2 00	3 00	4 00	5 00
Main & Pleasant Sts.	—	8 01	9 01	10 01	11 01	12 01	1 01	2 01	3 01	4 01	5 01
ar Gloucester Crossing	—	8 16	9 16	10 16	11 16	12 16	1 16	2 16	3 16	4 16	5 16
dp Gloucester Crossing	—	8 21	9 21	10 21	11 21	12 21	1 21	2 21	3 21	4 21	5 21
Blackburn (on request)	—	8 24	9 24	10 24	11 24	12 24	1 24	2 24	3 24	4 24	5 24

Blackburn Industrial Park

GLOUCESTER · O'Maley MS · GHS /
O'Maley MS · GLOUCESTER

AM	SCHOOL SERVICE		PM
—	7 32	7 33	O'MALEY MIDDLE SCHOOL*
6:58	—	—	Washington & Poplar Streets
6 59	—	—	Poplar St. & Maplewood Avenue
7 00	—	—	Maplewood & Gloucester Avenues
7 01	—	7 31	Maplewood Avenue & Grove St.
7 02	—	7 30	Maplewood Ave. & Cleveland St.
7 04	7 25	—	McDonald's®
—	—	—	Commuter Rail Station
7 06	—	—	Maplewood Avenue & Prospect St.
—	—	7 26	McPherson Park
—	—	7 25	Washington & Prospect Streets
—	—	7 24	Commuter Rail Station
—	—	—	McPherson Park
7 07	—	7 22	Prospect & Pleasant Streets
7 08	—	7 21	Prospect & Warner Streets
7 09	—	—	Destino's
7 10	—	7 19	Dunkin' Donuts / Rogers Street
—	—	—	Dunkin' Donuts
7 15	—	—	GLOUCESTER HIGH SCHOOL†

*Additional stops hourly at Mill Pond Medical Building at 2:27, 3:27 and 4:27 p.m.

†Additional service hourly from 8:07 a.m. until 5:07 p.m.
See main timetable at right.

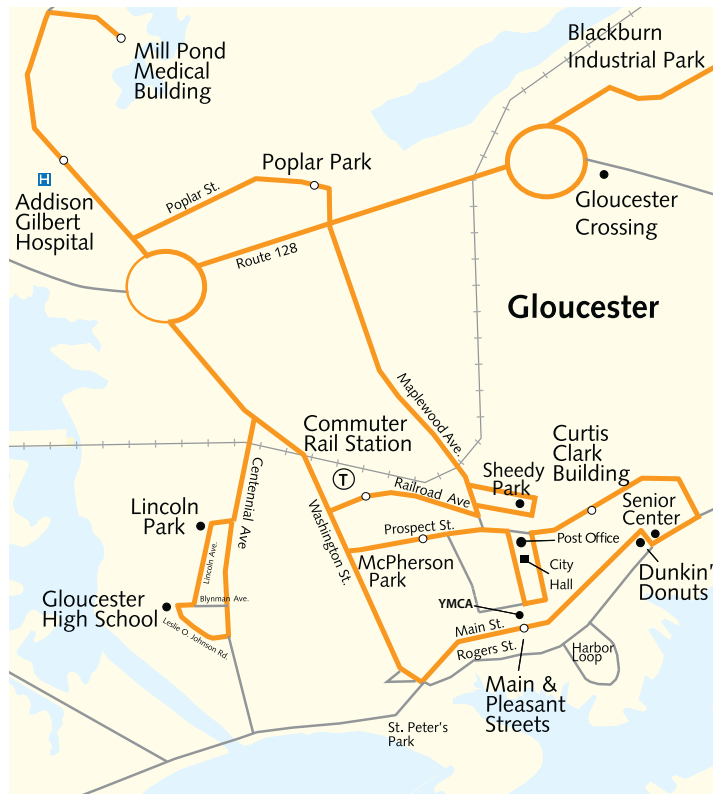

Gloucester Crossing & Business Express Loop

MONDAY THROUGH FRIDAY										
Dunkin' Donuts	8 00	9 00	10 00	11 00	12 00	1 00	2 00	3 00	4 00	5 00
Main & Pleasant Streets	8 01	9 01	10 01	11 01	12 01	1 01	2 01	3 01	4 01	5 01
Lincoln Park	8 06	9 06	10 06	11 06	12 06	1 06	2 06	3 06	4 06	5 06
GLOU. HIGH SCHOOL	8 07	9 07	10 07	11 07	12 07	1 07	2 07	3 07	4 07	5 07
arr Gloucester Crossing	8 16	9 16	10 16	11 16	12 16	1 16	2 16	3 16	4 16	5 16
dep Glou. Crossing	8 21	9 21	10 21	11 21	12 21	1 21	2 21	3 21	4 21	5 21
Blackburn (on request)	8 24	9 24	10 24	11 24	12 24	1 24	2 24	3 24	4 24	5 24
Mill Pond Medical Bldg.	8 27	9 27	10 27	11 27	12 27	1 27	2 27	3 27	4 27	5 27
Addison Gilbert Hosp.	8 29	9 29	10 29	11 29	12 29	1 29	2 29	3 29	4 29	5 29
Poplar Park	8 31	9 31	10 31	11 31	12 31	1 31	2 31	3 31	4 31	5 31
Sheedy Park	8 37	9 37	10 37	11 37	12 37	1 37	2 37	3 37	4 37	5 37
Commuter Rail Station	8 41	9 41	10 41	11 41	12 41	1 41	2 41	3 41	4 41	5 41
McPherson Park	8 43	9 43	10 43	11 43	12 43	1 43	2 43	3 43	4 43	
Post Office / City Hall	8 44	9 44	10 44	11 44	12 44	1 44	2 44	3 44	4 44	
YMCA Dale Ave & Middle St.	8 45	9 45	10 45	11 45	12 45	1 45	2 45	3 45	4 45	
Curtis B. Clark Building	8 48	9 48	10 48	11 48	12 48	1 48	2 48	3 48	4 48	
Dunkin' Donuts/Sr. Ctr.	8 50	9 50	10 50	11 50	12 50	1 50	2 50	3 50	4 50	

SATURDAY										
Dunkin' Donuts	—	9 00	10 00	11 00	12 00	1 00	2 00	3 00		
Main & Pleasant Streets	—	9 01	10 01	11 01	12 01	1 01	2 01	3 01		
Lincoln Park	—	9 06	10 06	11 06	12 06	1 06	2 06	3 06		
GLOU. HIGH SCHOOL	—	9 07	10 07	11 07	12 07	1 07	2 07	3 07		
arr Gloucester Crossing	—	9 16	10 16	11 16	12 16	1 16	2 16	3 16		
depart Glou. Crossing	—	9 21	10 21	11 21	12 21	1 21	2 21	3 21		
Mill Pond Medical Bldg.	—	9 27	10 27	11 27	12 27	1 27	2 27	3 27		
Addison Gilbert Hosp.	—	9 29	10 29	11 29	12 29	1 29	2 29	3 29		
Poplar Park	—	9 31	10 31	11 31	12 31	1 31	2 31	3 31		
Sheedy Park	—	9 37	10 37	11 37	12 37	1 37	2 37	3 37		
Commuter Rail Station	—	9 41	10 41	11 41	12 41	1 41	2 41	3 41		
McPherson Park	—	9 43	10 43	11 43	12 43	1 43	2 43	3 43		
Post Office / City Hall	—	9 44	10 44	11 44	12 44	1 44	2 44	3 44		
YMCA Dale Ave & Middle St.	—	9 45	10 45	11 45	12 45	1 45	2 45	3 45		
Curtis B. Clark Building	—	9 48	10 48	11 48	12 48	1 48	2 48	3 48		
Dunkin' Donuts/Sr. Ctr.	—	9 50	10 50	11 50	12 50	1 50	2 50	3 50		

Cruiseship Trolley Route

Seasonal - April through October
 Frequency: every 15 minutes
 (see map supplement)

Cruiseport Gloucester
 Main & Pleasant Streets
 Main & Hancock Streets
 Washington & Rogers Streets
 Middle Street & Western Avenue
 Rogers & Hancock Streets
 Rogers Street & Harbor Loop
 Cruiseport Gloucester

Gloucester Crossing & Business Express

Cruiseship Trolley

ROCKPORT · O'Maley MS · GHS · GLOUCESTER /
GLOUCESTER · GHS · O'Maley MS · ROCKPORT

AM		SCHOOL SERVICE	PM	
—	—	Dock Sq. / Toad Hall Bookstore	—	3 01 4 01
6 45	—	Rockport Market	2 46	3 00 4 00
6 46	—	Dock Sq. / Toad Hall Bookstore	—	— —
6 49	—	Commuter Rail Station	2 43	2 57 3 58
6 52	—	Pigeon Cove Post Office	2 40	2 54 3 55
6 55	—	Washington & Woodbury Streets	2 37	2 39 — 3 53
6 56	—	Langsford St. & Rockwood Lane	—	— —
6 57	—	Langsford St. & Norseman Ave.	—	— —
—	—	Washington St. & Munsey Lane	2 35	— —
—	—	Langsford & Andrews Streets	—	2 37 — 3 51
6 58	—	Lanesville Post Office	2 33	2 48 3 51
7 00	—	Bay View Fire Station	2 30	2 34 — 3 48
—	6 58	Washington & Colburn Streets	—	— —
—	7 00	Washington & Revere Streets	—	— —
7 02	7 02	Annisquam Village Church	2 29	2 33 2 44 3 47
7 03	—	Annisquam Wooden Bridge	2 28	2 32 — 3 46
7 04	—	Washington & Dennison Streets	2 26	2 30 — 3 44
—	7 05	Willow Rest	2 25	2 29 — 3 43
—	7:21	Centennial & Commonwealth Av	—	— —
—	7:23	Centennial Ave. & Exchange St.	—	— —
—	7 24	Washington & Grove Streets	—	— —
—	7 25	Washington St. & Madison Ave.	—	— —
—	7 25	Washington St & Gloucester Ave	—	— —
—	7 06	Washington & Stanwood Streets	—	2 41 —
—	7 29	Stanwood Street & Gee Avenue	—	2 28 — 3 42
—	7 07	Gee Avenue & Cherry Street	—	2 40 —
—	7 08	Cherry Street & Cherry Hill Road	—	2 27 2 39 3 41
—	7 09	Cherry Street & Finch Lane	—	2 26 2 38 3 40
—	7 11	Cherry & Reynard Streets	—	2 24 2 36 3 39
—	7 33	O'MALEY MIDDLE SCHOOL	—	2 32 —
7 08	—	Washington & Hodgkins Streets	—	— —
7 09	—	Washington & Wheeler Streets	2 22	2 22 2 29 3 36
7 10	—	Addison Gilbert Hospital	2 21	2 21 2 28 3 35
7 11	—	Washington & Poplar Streets	2 20	2 20 — 3 34
7 13	—	Commuter Rail Station	—	— —
7 18	7 18	GLOUCESTER HIGH SCHOOL	2 15	2 15 — 3 30
—	—	Commuter Rail Station	—	2 25 3 25
—	—	Main & Pleasant Streets	—	2 21 3 21
7 23	—	arrive Dunkin' Donuts	—	— —
7 25	—	depart Dunkin' Donuts	—	2 20 3 20
7 26	—	Main & Pleasant Streets	—	— —

School Day

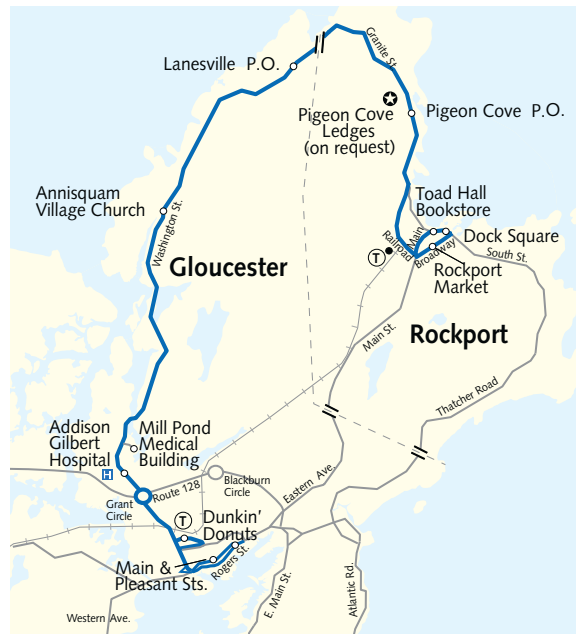

GLOUCESTER · ROCKPORT via Lanesville

	MONDAY THROUGH FRIDAY								NON-SCHOOL			
Dunkin' Donuts	7 25	9 25	11 25	1 20	2 20	3 30	4 25	5 25	—	—	—	—
Main & Pleasant Streets	7 26	9 26	11 26	1 21	2 21	3 31	4 26	5 26	—	—	—	—
Commuter Rail Station	7 30	9 30	11 30	1 25	2 25	3 35	4 30	5 30	5 57	6 22	—	—
Addison Gilbert Hospital	7 33	9 33	11 33	1 28	2 28	3 38	4 33	5 33	6 00	6 25	—	—
Annisquam Village Church	7 39	9 39	11 39	1 34	2 34	3 44	4 39	5 39	6 06	6 31	—	—
Lanesville Post Office	7 42	9 42	11 42	1 37	2 37	3 47	4 42	5 42	6 09	6 34	—	—
Pigeon Cove Post Office	7 48	9 48	11 48	1 43	2 43	3 53	4 48	5 48	6 15	6 40	—	—
Commuter Rail Station	7 51	9 51	11 51	1 46	2 46	3 56	4 51	5 51	6 18	6 43	—	—
arrive Rockport Market	7 54	9 54	11 54	1 49	2 49	3 59	4 54	5 54	6 21	6 46	—	—
depart Rockport Market	7 55	10 00	12 00	2 00	2 49	4 00	4 55	5 55	6 21	6 46	—	—
Dock Square	7 56	10 01	12 01	2 01	2 50	4 01	4 56	5 56	6 22	6 47	—	—
Toad Hall Bookstore	7 56	10 01	12 01	2 01	2 50	4 01	4 56	5 56	6 22	6 47	—	—

	SATURDAY											
Dunkin' Donuts	—	9 30	11 25	1 25	—	3 25	—	5 20	—	—	—	—
Main & Pleasant Streets	—	9 31	11 26	1 26	—	3 26	—	5 21	—	—	—	—
Commuter Rail Station	—	9 35	11 30	1 30	—	3 30	—	5 25	—	—	—	—
Addison Gilbert Hospital	—	9 38	11 33	1 33	—	3 33	—	5 28	—	—	—	—
Annisquam Village Church	—	9 44	11 39	1 39	—	3 39	—	5 34	—	—	—	—
Lanesville Post Office	—	9 47	11 42	1 42	—	3 42	—	5 37	—	—	—	—
Pigeon Cove Post Office	—	9 53	11 48	1 48	—	3 48	—	5 43	—	—	—	—
Commuter Rail Station	—	9 56	11 51	1 51	—	3 51	—	5 46	—	—	—	—
arrive Rockport Market	—	9 59	11 54	1 54	—	3 54	—	5 49	—	—	—	—
depart Rockport Market	—	10 00	12 00	2 00	—	4 00	—	5 49	—	—	—	—
Dock Square	—	10 01	12 01	2 01	—	4 01	—	5 50	—	—	—	—
Toad Hall Bookstore	—	10 01	12 01	2 01	—	4 01	—	5 50	—	—	—	—

ROCKPORT · GLOUCESTER via Lanesville

	MONDAY THROUGH FRIDAY								NON-SCHOOL			
Rockport Market	6 20	6 45	7 50	9 50	11 50	1 50	—	5 55	—	—	—	—
Dock Square	6 21	6 46	7 51	9 51	11 51	1 51	—	5 56	—	—	—	—
Toad Hall Bookstore	6 21	6 46	7 51	9 51	11 51	1 51	—	5 56	—	—	—	—
Commuter Rail Station	6 24	6 49	7 54	9 54	11 54	1 54	—	5 59	—	—	—	—
Pigeon Cove Post Office	6 27	6 52	7 57	9 57	11 57	1 57	—	6 02	—	—	—	—
Lanesville Post Office	6 33	6 58	8 03	10 03	12 03	2 03	—	6 08	—	—	—	—
Annisquam Village Church	6 36	7 01	8 06	10 06	12 06	2 06	—	6 11	—	—	—	—
Addison Gilbert Hospital	6 42	7 07	8 12	10 12	12 12	2 12	—	6 17	—	—	—	—
Commuter Rail Station	6 45	7 10	8 15	10 15	12 15	2 15	—	6 22	—	—	—	—
Dunkin' Donuts/Rogers St	—	—	—	—	—	—	—	6 26	—	—	—	—
arrive Dunkin' Donuts	—	7 15	8 20	10 20	12 20	2 20	—	—	—	—	—	—
depart Dunkin' Donuts	—	7 25	8 30	10 30	12 30	—	—	—	—	—	—	—
Main & Pleasant Streets	—	7 26	8 31	10 31	12 31	—	—	—	—	—	—	—

	SATURDAY											
Rockport Market	—	—	8 25	9 55	11 55	1 55	3 55	—	—	—	—	—
Dock Square	—	—	8 26	9 56	11 56	1 56	3 56	—	—	—	—	—
Toad Hall Bookstore	—	—	8 26	9 56	11 56	1 56	3 56	—	—	—	—	—
Commuter Rail Station	—	—	8 29	9 56	11 56	1 56	3 56	—	—	—	—	—
Pigeon Cove Post Office	—	—	8 32	9 59	11 59	1 59	3 59	—	—	—	—	—
Lanesville Post Office	—	—	8 38	10 02	12 02	2 02	4 02	—	—	—	—	—
Annisquam Village Church	—	—	8 41	10 11	12 11	2 11	4 11	—	—	—	—	—
Addison Gilbert Hospital	—	—	8 47	10 17	12 17	2 17	4 17	—	—	—	—	—
Commuter Rail Station	—	—	8 50	10 20	12 20	2 20	4 20	—	—	—	—	—
arrive Dunkin' Donuts	—	—	8 55	10 25	12 25	2 25	4 25	—	—	—	—	—
depart Dunkin' Donuts	—	—	9 00	10 30	—	2 30	4 30	—	—	—	—	—
Main & Pleasant Streets	—	—	9 01	10 31	—	2 31	4 31	—	—	—	—	—

Rockport via Lanesville

APPENDIX D
Zoning Map
City of Gloucester

Ipswich Bay

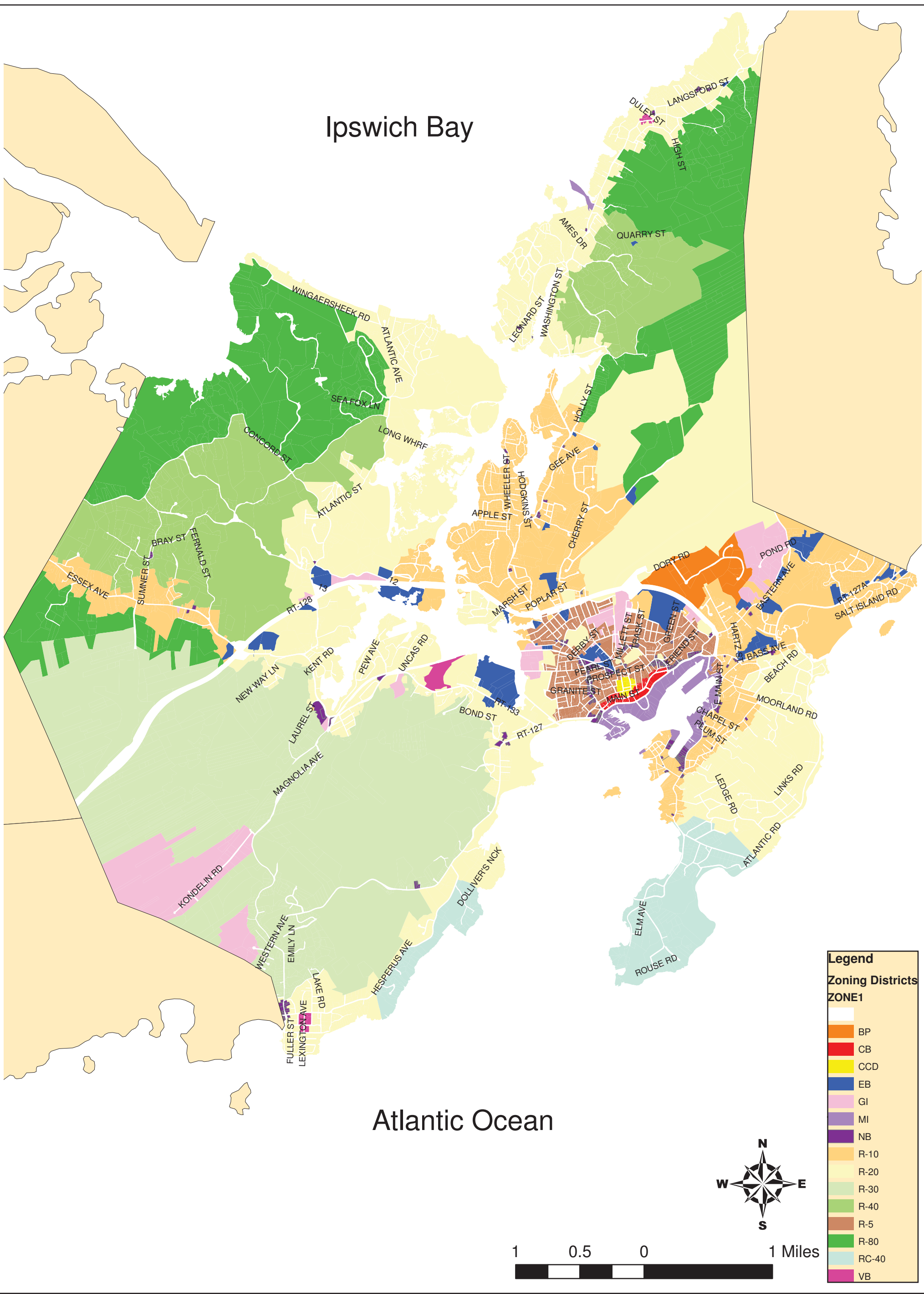

Atlantic Ocean

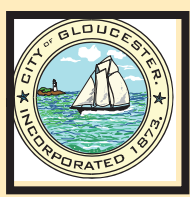

Zoning Map

Figure 7

APPENDIX E
Zoning Map
Town of Rockport

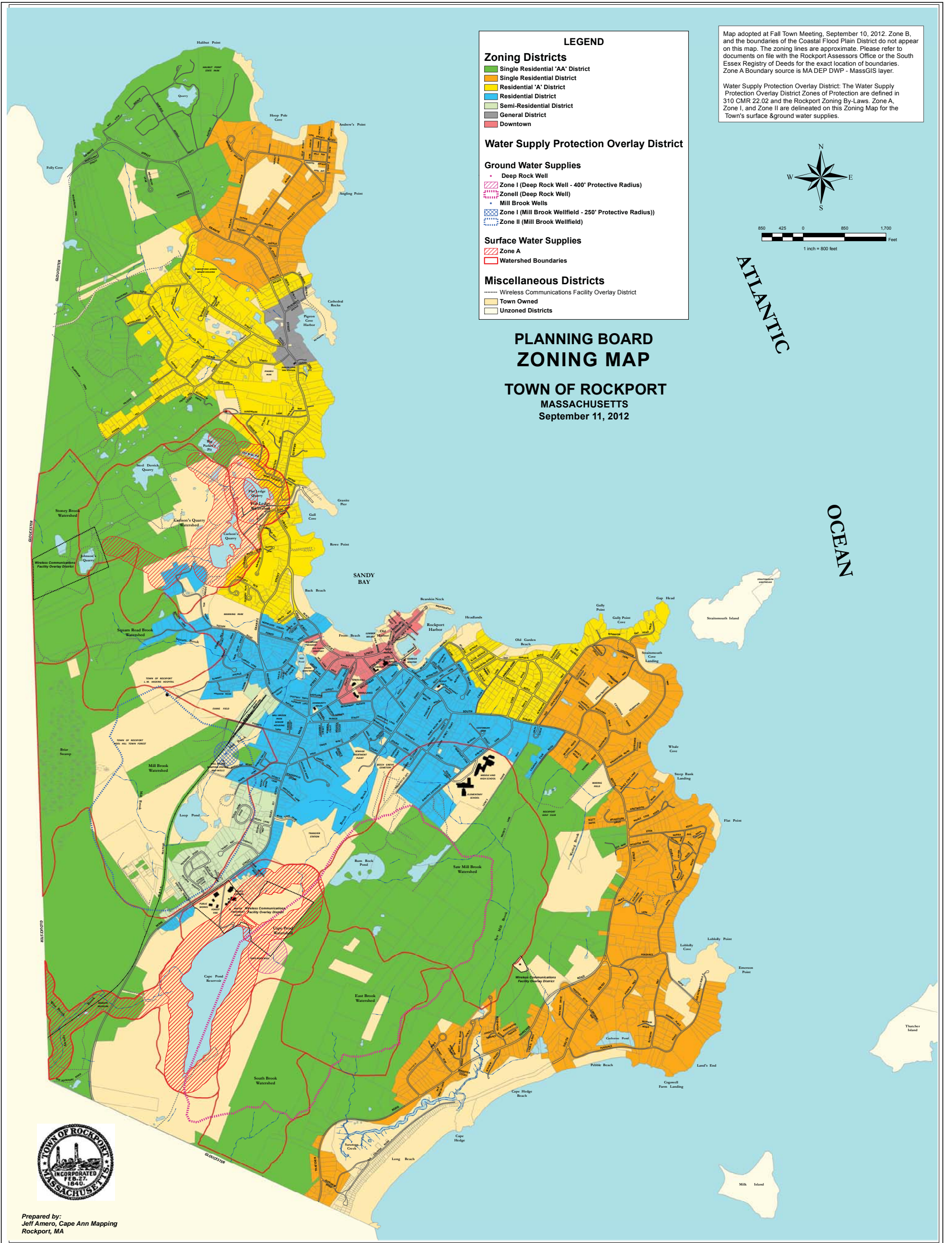

LEGEND

Zoning Districts

- Single Residential 'AA' District
- Single Residential District
- Residential 'A' District
- Residential District
- Semi-Residential District
- General District
- Downtown

Water Supply Protection Overlay District

Ground Water Supplies

- Deep Rock Well
- Zone I (Deep Rock Well - 400' Protective Radius)
- Zonell (Deep Rock Well)
- Mill Brook Wells
- Zone I (Mill Brook Wellfield - 250' Protective Radius)
- Zone II (Mill Brook Wellfield)

Surface Water Supplies

- Zone A
- Watershed Boundaries

Miscellaneous Districts

- Wireless Communications Facility Overlay District
- Town Owned
- Unzoned Districts

Map adopted at Fall Town Meeting, September 10, 2012. Zone B, and the boundaries of the Coastal Flood Plain District do not appear on this map. The zoning lines are approximate. Please refer to documents on file with the Rockport Assessors Office or the South Essex Registry of Deeds for the exact location of boundaries. Zone A Boundary source is MA DEP DWP - MassGIS layer.

Water Supply Protection Overlay District: The Water Supply Protection Overlay District Zones of Protection are defined in 310 CMR 22.02 and the Rockport Zoning By-Laws. Zone A, Zone I, and Zone II are delineated on this Zoning Map for the Town's surface & ground water supplies.

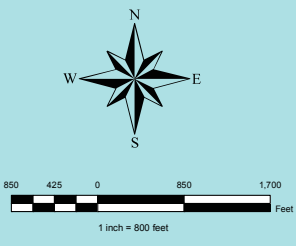

**PLANNING BOARD
ZONING MAP
TOWN OF ROCKPORT
MASSACHUSETTS
September 11, 2012**

ATLANTIC OCEAN



Prepared by:
Jeff Amero, Cape Ann Mapping
Rockport, MA

APPENDIX F
Cape Ann Trail Map
Metropolitan Area Planning Council

Cape Ann Trail Map

Regional facilities

- Regional Greenway (proposed) █
- Regional walking trail (proposed) █

	Proposed	Existing
Shared-use paths		
Improved path	-----	———
Unimproved path	-----	———

Bicycle facilities (on-road)

Cycle track	-----	———
Bike lane	-----	———
Shared lane	-----	———
On-road route	-----	———

	Proposed	Existing
Walking facilities		
Walking path or trail	-----	———

Water facilities

Water trail	-----	———
-------------	-------	-----

0 1,000 Feet



2

- █ Fairmount Greenway
- Building
- Municipal boundary
- Water body
- Open space

Data Sources: MAPC, MassGIS, MassDOT

January, 2014



APPENDIX G

Average Weekday and Summer Weekend Day Traffic Volume Estimates

Summary of Average Weekday and Summer Weekend Day Traffic Estimates

STA 1: Route 127A (Bass Ave) W. of Atlantic Rd

Average Weekday Traffic

	Average	Adjusted	Peak-Hour	PH/24-Hr
NB	4423	4000	320	0.08
SB	4904	4400	360	0.08
Sum	9327	8400	680	0.08

Average Summer Weekend Day Traffic

	7/13 Sat	7/14 Sun	Average	Peak Hour	PH/24-Hr
NB	4599	5478	5000	370	0.07
SB	5206	5608	5400	515	0.10
Sum	9805	11086	10400	885	0.09

Summer Weekend /Average Weekday

Daily Traffic	Peak Hour Traffic
125%	116%
123%	143%
124%	130%

STA 2: Route 127A (Thatcher Rd) W. of Bass Ave

Average Weekday Traffic

	Average	Adjusted	Peak-Hour	PH/24-Hr
NB	4550	4100	370	0.09
SB	4610	4200	370	0.09
Sum	9160	8300	740	0.09

Average Summer Weekend Day Traffic

	7/13 Sat	7/14 Sun	Average	Peak Hour	PH/24-Hr
NB	4994	5304	5100	550	0.11
SB	4908	5275	5100	410	0.08
Sum	9902	10579	10200	960	0.09

Summer Weekend /Average Weekday

Daily Traffic	Peak Hour Traffic
124%	149%
121%	111%
123%	130%

STA 3: Route 127A (Thatcher Rd) at Good Harbor Beach

Average Weekday Traffic

	Average	Adjusted	Peak-Hour	PH/24-Hr
NB	5410	4900	470	0.10
SB	5185	4700	440	0.09
Sum	10595	9600	910	0.09

Average Summer Weekend Day Traffic

	7/13 Sat	7/14 Sun	Average	Peak Hour	PH/24-Hr
NB	9007	9683	9300	650	0.07
SB	9975	9674	9800	700	0.07
Sum	18982	19357	19100	1350	0.07

Summer Weekend /Average Weekday

Daily Traffic	Peak Hour Traffic
190%	138%
209%	159%
199%	148%

STA 4: Route 127A (Thatcher Rd) N. of Glenmere Rd

Average Weekday Traffic

	Average	Adjusted	Peak-Hour	PH/24-Hr
NB	2850	2600	250	0.10
SB	2327	2100	150	0.07
Sum	5177	4700	400	0.09

Average Summer Weekend Day Traffic

	7/13 Sat	7/14 Sun	Average	Peak Hour	PH/24-Hr
NB	3381	3097	3200	290	0.09
SB	2689	2634	2700	200	0.07
Sum	6070	5731	5900	490	0.08

Summer Weekend /Average Weekday

Daily Traffic	Peak Hour Traffic
123%	116%
129%	133%
126%	123%

STA 5: Route 127A (Thatcher Rd) S. of Oakes Lane

Average Weekday Traffic

	Average	Adjusted	Peak-Hour	PH/24-Hr
NB	2653	2400	210	0.09
SB	2512	2300	170	0.07
Sum	5165	4700	380	0.08

Average Summer Weekend Day Traffic

	7/13 Sat	7/14 Sun	Average	Peak Hour	PH/24-Hr
NB	2969	2868	2900	250	0.09
SB	2420	2555	2500	240	0.10
Sum	5389	5423	5400	490	0.09

Summer Weekend /Average Weekday

Daily Traffic	Peak Hour Traffic
121%	119%
109%	141%
115%	129%

STA 6: Route 127 (Main St) S. of Parker St

Average Weekday Traffic

	Average	Adjusted	Peak-Hour	PH/24-Hr
NB	6688	6000	510	0.09
SB	6784	6100	420	0.07
Sum	13472	12100	930	0.08

Average Summer Weekend Day Traffic

	7/13 Sat	7/14 Sun	Average	Peak Hour	PH/24-Hr
NB	7012	6254	6600	570	0.09
SB	6674	6315	6500	510	0.08
Sum	13686	12569	13100	1080	0.08

Summer Weekend /Average Weekday

Daily Traffic	Peak Hour Traffic
110%	112%
107%	121%
108%	116%

STA 7: Route 127 (Broadway) N. of School St

Average Weekday Traffic

	Average	Adjusted	Peak-Hour	PH/24-Hr
NB	2637	2400	170	0.07
SB	5028	4500	370	0.08
Sum	7665	6900	540	0.08

Average Summer Weekend Day Traffic

	7/13 Sat	7/14 Sun	Average	Peak Hour	PH/24-Hr
NB	2904	2157	2600	240	0.09
SB	7522	7125	7300	700	0.10
Sum	10426	9282	9900	940	0.09

Summer Weekend /Average Weekday

Daily Traffic	Peak Hour Traffic
108%	141%
162%	189%
143%	174%

STA 8: Route 127 (Mt. Pleasant St) S. of Broadway

Average Weekday Traffic

	Average	Adjusted	Peak-Hour	PH/24-Hr
NB	3994	3600	280	0.08
SB	2948	2700	210	0.08
Sum	6942	6300	490	0.08

Average Summer Weekend Day Traffic

	7/13 Sat	7/14 Sun	Average	Peak Hour	PH/24-Hr
NB	4815	4478	4700	410	0.09
SB	3543	3446	3500	340	0.10
Sum	8358	7924	8200	750	0.09

Summer Weekend /Average Weekday

Daily Traffic	Peak Hour Traffic
131%	146%
130%	162%
130%	153%

STA 9: Main St E. of Beach St (One-way WB only)

Average Weekday Traffic

	Average	Adjusted	Peak-Hour	PH/24-Hr
WB	2211	2000	170	0.09

Average Summer Weekend Day Traffic

	7/13 Sat	7/14 Sun	Average	Peak Hour	PH/24-Hr
NB	2692	3082	2900	270	0.09

Summer Weekend /Average Weekday

Daily Traffic	Peak Hour Traffic
145%	159%

STA 10: Beach St E. of Route 127 (Granite St)

Average Weekday Traffic

	Average	Adjusted	Peak-Hour	PH/24-Hr
NB	1703	1500	140	0.09
SB	643	600	50	0.08
Sum	2346	2100	190	0.09

Average Summer Weekend Day Traffic

	7/13 Sat	7/14 Sun	Average	Peak Hour	PH/24-Hr
NB	1935	2218	2100	180	0.09
SB	834	1063	900	80	0.09
Sum	2769	3281	3000	260	0.09

Summer Weekend /Average Weekday

Daily Traffic	Peak Hour Traffic
140%	129%
150%	160%
143%	137%

STA 11: Route 127 (Granite St) N. of Beach St

Average Weekday Traffic

	Average	Adjusted	Peak-Hour	PH/24-Hr
NB	4113	3700	350	0.09
SB	3911	3500	280	0.08
Sum	8024	7200	630	0.09

Average Summer Weekend Day Traffic

	7/13 Sat	7/14 Sun	Average	Peak Hour	PH/24-Hr
NB	4366	4327	4300	360	0.08
SB	4153	3981	4100	320	0.08
Sum	8519	8308	8400	680	0.08

Summer Weekend /Average Weekday

Daily Traffic	Peak Hour Traffic
116%	103%
117%	114%
117%	108%

STA 12: Route 127 (Granite St) N. of Woodbury Hill

Average Weekday Traffic

	Average	Adjusted	Peak-Hour	PH/24-Hr
NB	1501	1400	140	0.10
SB	1639	1500	140	0.09
Sum	3140	2900	280	0.10

Average Summer Weekend Day Traffic

	7/13 Sat	7/14 Sun	Average	Peak Hour	PH/24-Hr
NB	1745	1773	1800	170	0.09
SB	1910	2069	2000	180	0.09
Sum	3655	3842	3800	350	0.09

Summer Weekend /Average Weekday

Daily Traffic	Peak Hour Traffic
129%	121%
133%	129%
131%	125%

STA 13: Route 127 (Langsford St) S. of Andrews St

Average Weekday Traffic

	Average	Adjusted	Peak-Hour	PH/24-Hr
NB	1634	1500	120	0.08
SB	1327	1200	110	0.09
Sum	2961	2700	230	0.09

Average Summer Weekend Day Traffic

	7/13 Sat	7/14 Sun	Average	Peak Hour	PH/24-Hr
NB	1768	1808	1800	150	0.08
SB	1274	1132	1500	130	0.09
Sum	3042	2940	3300	280	0.08

Summer Weekend /Average Weekday

Daily Traffic	Peak Hour Traffic
120%	125%
125%	118%
122%	122%

STA 14: Route 127 (Washington St) S. of Stanwood St

Average Weekday Traffic

	Average	Adjusted	Peak-Hour	PH/24-Hr
NB	4526	4100	280	0.07
SB	4991	4500	420	0.09
Sum	9517	8600	700	0.08

Average Summer Weekend Day Traffic

	7/13 Sat	7/14 Sun	Average	Peak Hour	PH/24-Hr
NB	4507	4275	4400	320	0.07
SB	4916	4538	4700	400	0.09
Sum	9423	8813	9100	720	0.08

Summer Weekend /Average Weekday

APPENDIX H

Turning Movement Counts Saturday, July 13, 2013, 10:00 AM – 2:00 PM

Location 1

Rt127A (Thatcher Rd./Bass Ave.) at Atlantic Rd., Gloucester

Location 2

Rt127A (Thatcher Rd.) at Barn Ln., Gloucester

Location 3

Rt127A (Thatcher Rd.) at Witham St., Gloucester

Location 4

Rt127A (Mt. Pleasant St./Broadway) at T-Wharf, Rockport

Location 5

Dock Square (Mt. Pleasant St. at Main St.), Rockport

Location 6:

Route 127 (Washington St.) at Stanwood St., Gloucester

Massachusetts Department of Transportation

Highway Division

Statewide Traffic Data Collection

Gloucester
 Bass Ave. @ Thatcher & Atlantic Rds.
 Counted by Miovision
 S13-037 TMC # 1

File Name : S13-037 1 Gloucester
 Site Code : 119272
 Start Date : 7/13/2013
 Page No : 1

Groups Printed- Car - Truck

Start Time	Route 127A Thatcher Road From North				Bass Avenue From East				Atlantic Road From South				Route 127A Bass Avenue From West				Int. Total
	Right	Thru	Left	App. Total	Right	Thru	Left	App. Total	Right	Thru	Left	App. Total	Right	Thru	Left	App. Total	
10:00 AM	39	21	8	68	0	1	0	1	2	24	31	57	16	27	36	79	205
10:15 AM	42	21	8	71	1	2	0	3	4	35	40	79	10	18	39	67	220
10:30 AM	38	31	14	83	0	0	1	1	8	33	31	72	13	17	47	77	233
10:45 AM	52	30	7	89	1	1	0	2	4	27	31	62	22	19	47	88	241
Total	171	103	37	311	2	4	1	7	18	119	133	270	61	81	169	311	899
11:00 AM	47	23	17	87	0	1	0	1	3	30	31	64	17	29	50	96	248
11:15 AM	50	19	8	77	2	0	0	2	7	30	52	89	15	23	55	93	261
11:30 AM	33	36	16	85	4	2	0	6	3	43	33	79	20	23	53	96	266
11:45 AM	49	21	13	83	4	2	0	6	3	45	28	76	22	35	51	108	273
Total	179	99	54	332	10	5	0	15	16	148	144	308	74	110	209	393	1048
12:00 PM	46	24	16	86	1	0	0	1	14	36	32	82	23	31	43	97	266
12:15 PM	39	18	12	69	0	0	1	1	10	33	50	93	19	26	38	83	246
12:30 PM	39	25	9	73	1	1	0	2	4	28	28	60	23	30	45	98	233
12:45 PM	30	22	10	62	0	2	0	2	6	48	22	76	18	35	68	121	261
Total	154	89	47	290	2	3	1	6	34	145	132	311	83	122	194	399	1006
01:00 PM	50	29	11	90	0	0	0	0	5	27	29	61	17	31	54	102	253
01:15 PM	57	20	16	93	0	0	0	0	7	40	31	78	22	27	56	105	276
01:30 PM	41	22	10	73	2	3	0	5	8	37	24	69	25	21	52	98	245
01:45 PM	52	19	7	78	1	2	0	3	6	48	37	91	18	28	45	91	263
Total	200	90	44	334	3	5	0	8	26	152	121	299	82	107	207	396	1037
Grand Total	704	381	182	1267	17	17	2	36	94	564	530	1188	300	420	779	1499	3990
Apprch %	55.6	30.1	14.4		47.2	47.2	5.6		7.9	47.5	44.6		20	28	52		
Total %	17.6	9.5	4.6	31.8	0.4	0.4	0.1	0.9	2.4	14.1	13.3	29.8	7.5	10.5	19.5	37.6	
Car	692	379	178	1249	17	17	2	36	94	557	526	1177	298	415	771	1484	3946
% Car	98.3	99.5	97.8	98.6	100	100	100	100	100	98.8	99.2	99.1	99.3	98.8	99	99	98.9
Truck	12	2	4	18	0	0	0	0	0	7	4	11	2	5	8	15	44
% Truck	1.7	0.5	2.2	1.4	0	0	0	0	0	1.2	0.8	0.9	0.7	1.2	1	1	1.1

Massachusetts Department of Transportation

Highway Division

Statewide Traffic Data Collection

Gloucester
 Thatcher Rd (Rte 127A) & Barn Lane
 Counted by Miovision
 S13-037 TMC # 2

File Name : S13-037 2 Gloucester
 Site Code : 119285
 Start Date : 7/13/2013
 Page No : 1

Groups Printed- Car - Truck

Start Time	Route 127A From North			Route 127A From South			Barn Lane From West			Int. Total
	Right	Thru	App. Total	Thru	Left	App. Total	Right	Left	App. Total	
10:00 AM	30	40	70	33	31	64	34	37	71	205
10:15 AM	30	53	83	51	25	76	22	33	55	214
10:30 AM	22	48	70	57	26	83	20	46	66	219
10:45 AM	22	72	94	53	38	91	35	31	66	251
Total	104	213	317	194	120	314	111	147	258	889
11:00 AM	22	44	66	61	32	93	33	36	69	228
11:15 AM	16	44	60	66	26	92	29	42	71	223
11:30 AM	23	48	71	62	30	92	28	52	80	243
11:45 AM	22	57	79	75	29	104	20	36	56	239
Total	83	193	276	264	117	381	110	166	276	933
12:00 PM	23	54	77	58	32	90	30	38	68	235
12:15 PM	24	45	69	59	23	82	36	40	76	227
12:30 PM	23	40	63	47	29	76	28	48	76	215
12:45 PM	17	39	56	88	38	126	24	38	62	244
Total	87	178	265	252	122	374	118	164	282	921
01:00 PM	17	53	70	62	29	91	35	43	78	239
01:15 PM	32	55	87	63	33	96	35	40	75	258
01:30 PM	42	46	88	78	25	103	24	45	69	260
01:45 PM	29	59	88	61	28	89	23	49	72	249
Total	120	213	333	264	115	379	117	177	294	1006
Grand Total	394	797	1191	974	474	1448	456	654	1110	3749
Apprch %	33.1	66.9		67.3	32.7		41.1	58.9		
Total %	10.5	21.3	31.8	26	12.6	38.6	12.2	17.4	29.6	
Car	392	790	1182	966	463	1429	448	653	1101	3712
% Car	99.5	99.1	99.2	99.2	97.7	98.7	98.2	99.8	99.2	99
Truck	2	7	9	8	11	19	8	1	9	37
% Truck	0.5	0.9	0.8	0.8	2.3	1.3	1.8	0.2	0.8	1

Massachusetts Department of Transportation
Highway Division
 Statewide Traffic Data Collection

File Name : S13-037 2 Gloucester
 Site Code : 119285
 Start Date : 7/13/2013
 Page No : 2

Start Time	Route 127A From North			Route 127A From South			Barn Lane From West			Int. Total
	Right	Thru	App. Total	Thru	Left	App. Total	Right	Left	App. Total	
Peak Hour Analysis From 10:00 AM to 01:45 PM - Peak 1 of 1										
Peak Hour for Entire Intersection Begins at 01:00 PM										
01:00 PM	17	53	70	62	29	91	35	43	78	239
01:15 PM	32	55	87	63	33	96	35	40	75	258
01:30 PM	42	46	88	78	25	103	24	45	69	260
01:45 PM	29	59	88	61	28	89	23	49	72	249
Total Volume	120	213	333	264	115	379	117	177	294	1006
% App. Total	36	64		69.7	30.3		39.8	60.2		
PHF	.714	.903	.946	.846	.871	.920	.836	.903	.942	.967

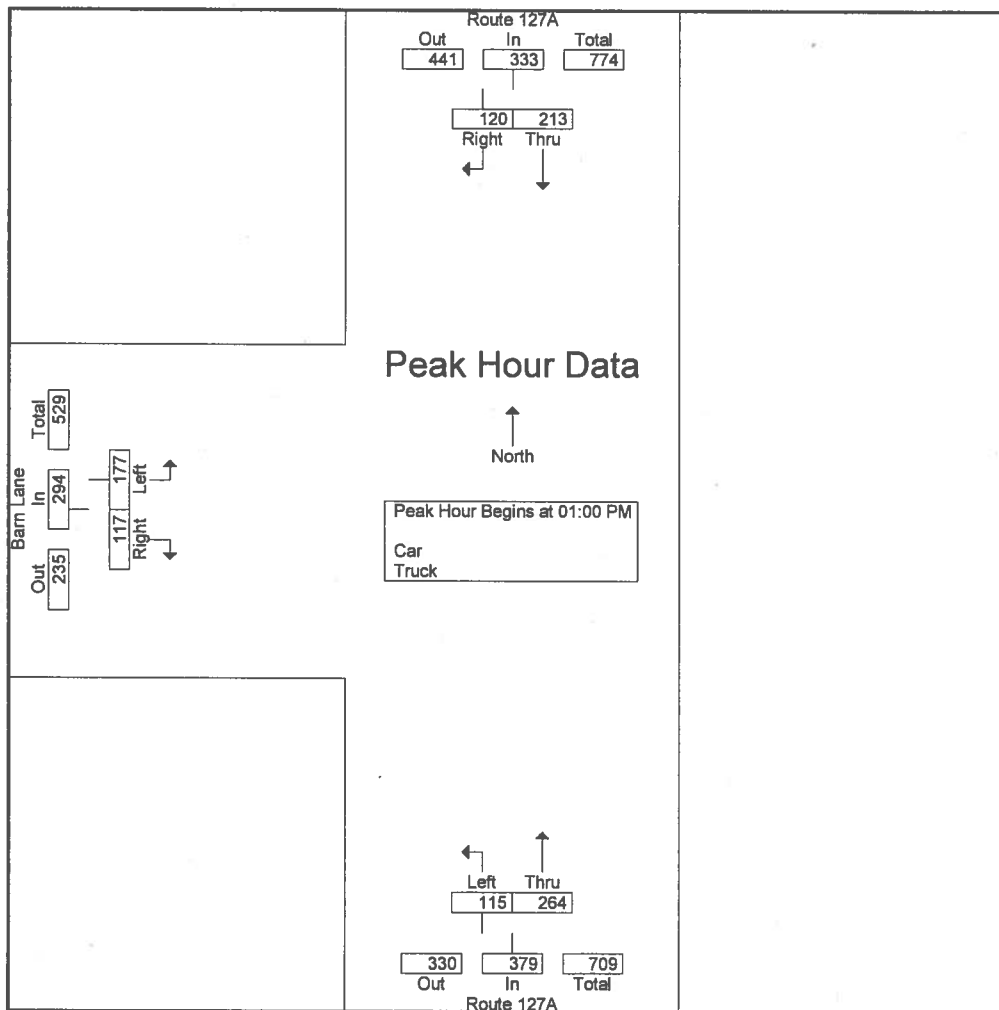

Massachusetts Department of Transportation

Highway Division

Statewide Traffic Data Collection

Gloucester
 Thatcher Rd (Rte 127A) & Barn Lane
 Counted by Miovision
 S13-037 TMC # 2

File Name : S13-037 2 Gloucester
 Site Code : 119285
 Start Date : 7/13/2013
 Page No : 1

Groups Printed- Car

Start Time	Route 127A From North			Route 127A From South			Barn Lane From West			Int. Total
	Right	Thru	App. Total	Thru	Left	App. Total	Right	Left	App. Total	
10:00 AM	29	40	69	33	30	63	33	37	70	202
10:15 AM	30	53	83	50	25	75	22	33	55	213
10:30 AM	22	48	70	57	25	82	20	45	65	217
10:45 AM	22	71	93	52	37	89	35	31	66	248
Total	103	212	315	192	117	309	110	146	256	880
11:00 AM	22	43	65	61	31	92	32	36	68	225
11:15 AM	16	44	60	66	24	90	28	42	70	220
11:30 AM	23	48	71	62	29	91	28	52	80	242
11:45 AM	22	56	78	75	29	104	19	36	55	237
Total	83	191	274	264	113	377	107	166	273	924
12:00 PM	23	54	77	58	32	90	29	38	67	234
12:15 PM	24	44	68	57	23	80	35	40	75	223
12:30 PM	23	39	62	47	27	74	28	48	76	212
12:45 PM	17	39	56	87	38	125	24	38	62	243
Total	87	176	263	249	120	369	116	164	280	912
01:00 PM	16	52	68	61	28	89	34	43	77	234
01:15 PM	32	55	87	61	33	94	35	40	75	256
01:30 PM	42	45	87	78	24	102	23	45	68	257
01:45 PM	29	59	88	61	28	89	23	49	72	249
Total	119	211	330	261	113	374	115	177	292	996
Grand Total	392	790	1182	966	463	1429	448	653	1101	3712
Apprch %	33.2	66.8		67.6	32.4		40.7	59.3		
Total %	10.6	21.3	31.8	26	12.5	38.5	12.1	17.6	29.7	

Massachusetts Department of Transportation

Highway Division

Statewide Traffic Data Collection

Gloucester
 Thatcher Rd (Rte 127A) & Barn Lane
 Counted by Miovision
 S13-037 TMC # 2

File Name : S13-037 2 Gloucester
 Site Code : 119285
 Start Date : 7/13/2013
 Page No : 1

Groups Printed- Truck

Start Time	Route 127A From North			Route 127A From South			Barn Lane From West			Int. Total
	Right	Thru	App. Total	Thru	Left	App. Total	Right	Left	App. Total	
10:00 AM	1	0	1	0	1	1	1	0	1	3
10:15 AM	0	0	0	1	0	1	0	0	0	1
10:30 AM	0	0	0	0	1	1	0	1	1	2
10:45 AM	0	1	1	1	1	2	0	0	0	3
Total	1	1	2	2	3	5	1	1	2	9
11:00 AM	0	1	1	0	1	1	1	0	1	3
11:15 AM	0	0	0	0	2	2	1	0	1	3
11:30 AM	0	0	0	0	1	1	0	0	0	1
11:45 AM	0	1	1	0	0	0	1	0	1	2
Total	0	2	2	0	4	4	3	0	3	9
12:00 PM	0	0	0	0	0	0	1	0	1	1
12:15 PM	0	1	1	2	0	2	1	0	1	4
12:30 PM	0	1	1	0	2	2	0	0	0	3
12:45 PM	0	0	0	1	0	1	0	0	0	1
Total	0	2	2	3	2	5	2	0	2	9
01:00 PM	1	1	2	1	1	2	1	0	1	5
01:15 PM	0	0	0	2	0	2	0	0	0	2
01:30 PM	0	1	1	0	1	1	1	0	1	3
Total	1	2	3	3	2	5	2	0	2	10
Grand Total	2	7	9	8	11	19	8	1	9	37
Apprch %	22.2	77.8		42.1	57.9		88.9	11.1		
Total %	5.4	18.9	24.3	21.6	29.7	51.4	21.6	2.7	24.3	

Massachusetts Department of Transportation

Highway Division

Statewide Traffic Data Collection

Gloucester
 Thatcher Rd (Rte 127A) & Barn Lane
 Counted by Miovision
 S13-037 TMC # 2

File Name : S13-037 2 Gloucester
 Site Code : 119285
 Start Date : 7/13/2013
 Page No : 1

Groups Printed- Pedal Bike (Road)

Start Time	Route 127A From North			Route 127A From South			Barn Lane From West			Int. Total
	Right	Thru	App. Total	Thru	Left	App. Total	Right	Left	App. Total	
10:00 AM	0	1	1	4	0	4	0	0	0	5
10:15 AM	0	1	1	8	0	8	0	0	0	9
10:30 AM	0	0	0	20	0	20	0	0	0	20
10:45 AM	0	1	1	5	0	5	0	0	0	6
Total	0	3	3	37	0	37	0	0	0	40
11:00 AM	0	0	0	2	0	2	0	0	0	2
11:15 AM	0	2	2	1	0	1	0	0	0	3
11:30 AM	0	2	2	3	0	3	0	0	0	5
11:45 AM	0	1	1	3	0	3	0	0	0	4
Total	0	5	5	9	0	9	0	0	0	14
12:00 PM	0	2	2	0	0	0	0	0	0	2
12:30 PM	0	2	2	0	0	0	0	0	0	2
12:45 PM	0	1	1	1	0	1	0	0	0	2
Total	0	5	5	1	0	1	0	0	0	6
01:00 PM	0	1	1	3	0	3	0	0	0	4
01:15 PM	0	1	1	7	0	7	0	1	1	9
01:30 PM	1	1	2	3	0	3	0	0	0	5
01:45 PM	0	2	2	2	0	2	0	0	0	4
Total	1	5	6	15	0	15	0	1	1	22
Grand Total	1	18	19	62	0	62	0	1	1	82
Apprch %	5.3	94.7		100	0		0	100		
Total %	1.2	22	23.2	75.6	0	75.6	0	1.2	1.2	

Massachusetts Department of Transportation

Highway Division

Statewide Traffic Data Collection

Gloucester
 Thatcher Rd (Rte 127A) & Barn Lane
 Counted by Miovision
 S13-037 TMC # 2

File Name : S13-037 2 Gloucester
 Site Code : 119285
 Start Date : 7/13/2013
 Page No : 1

Groups Printed- Ped

Start Time	Route 127A From North		Route 127A From South		Barn Lane From West		Int. Total
	Peds	App. Total	Peds	App. Total	Peds	App. Total	
10:15 AM	0	0	0	0	1	1	1
Total	0	0	0	0	1	1	1
11:15 AM	0	0	0	0	2	2	2
11:30 AM	0	0	0	0	1	1	1
11:45 AM	0	0	0	0	1	1	1
Total	0	0	0	0	4	4	4
Grand Total	0	0	0	0	5	5	5
Apprch %	0		0		100		
Total %	0		0		100	100	

Massachusetts Department of Transportation

Highway Division

Statewide Traffic Data Collection

File Name : S13-037 1 Gloucester

Site Code : 119272

Start Date : 7/13/2013

Page No : 2

Start Time	Route 127A Thatcher Road From North				Bass Avenue From East				Atlantic Road From South				Route 127A Bass Avenue From West				Int. Total
	Right	Thru	Left	App. Total	Right	Thru	Left	App. Total	Right	Thru	Left	App. Total	Right	Thru	Left	App. Total	
Peak Hour Analysis From 10:00 AM to 01:45 PM - Peak 1 of 1																	
Peak Hour for Entire Intersection Begins at 11:15 AM																	
11:15 AM	50	19	8	77	2	0	0	2	7	30	52	89	15	23	55	93	261
11:30 AM	33	36	16	85	4	2	0	6	3	43	33	79	20	23	53	96	266
11:45 AM	49	21	13	83	4	2	0	6	3	45	28	76	22	35	51	108	273
12:00 PM	46	24	16	86	1	0	0	1	14	36	32	82	23	31	43	97	266
Total Volume	178	100	53	331	11	4	0	15	27	154	145	326	80	112	202	394	1066
% App. Total	53.8	30.2	16		73.3	26.7	0		8.3	47.2	44.5		20.3	28.4	51.3		
PHF	.890	.694	.828	.962	.688	.500	.000	.625	.482	.856	.697	.916	.870	.800	.918	.912	.976

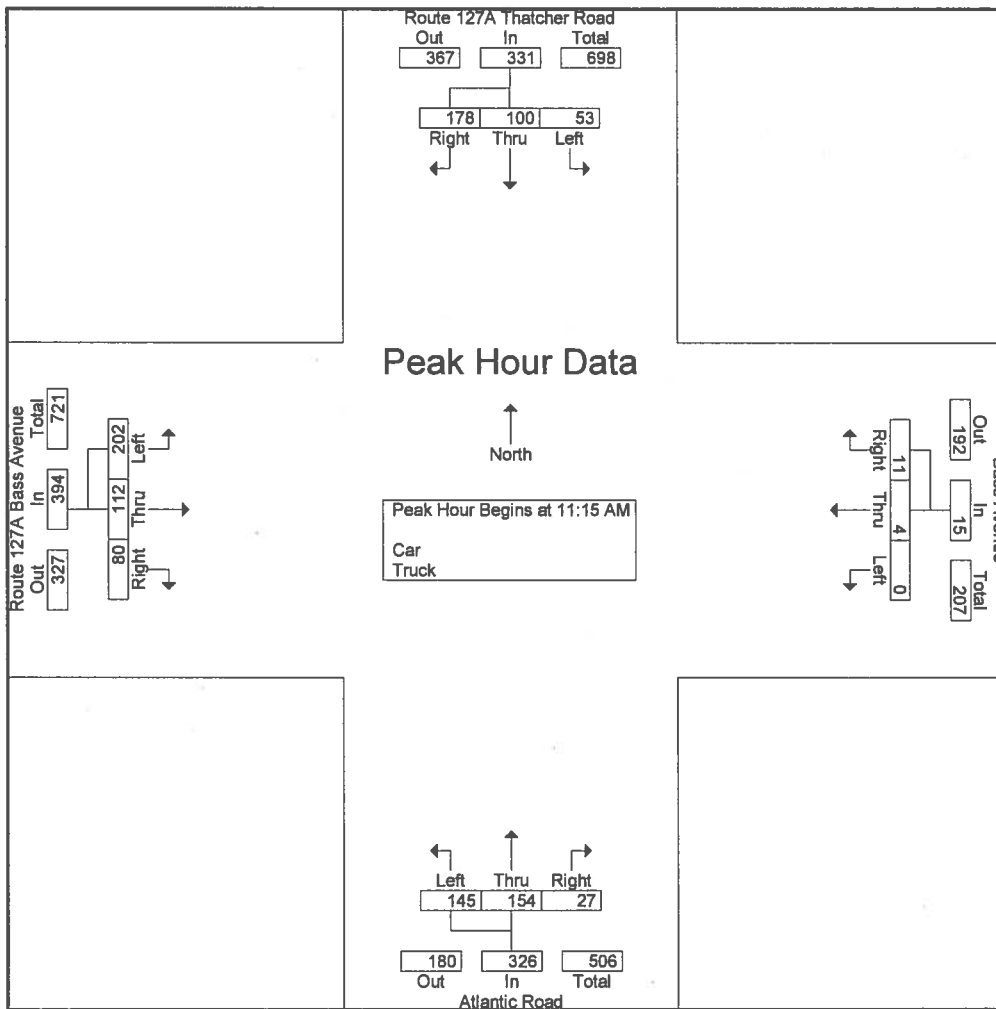

Massachusetts Department of Transportation

Highway Division

Statewide Traffic Data Collection

Gloucester
 Bass Ave. @ Thatcher & Atlantic Rds.
 Counted by Miovision
 S13-037 TMC # 1

File Name : S13-037 1 Gloucester
 Site Code : 119272
 Start Date : 7/13/2013
 Page No : 1

Groups Printed- Car

Start Time	Route 127A Thatcher Road From North				Bass Avenue From East				Atlantic Road From South				Route 127A Bass Avenue From West				Int. Total
	Right	Thru	Left	App. Total	Right	Thru	Left	App. Total	Right	Thru	Left	App. Total	Right	Thru	Left	App. Total	
10:00 AM	39	21	8	68	0	1	0	1	2	24	31	57	16	27	35	78	204
10:15 AM	40	21	8	69	1	2	0	3	4	35	39	78	10	17	38	65	215
10:30 AM	38	31	14	83	0	0	1	1	8	32	31	71	13	17	46	76	231
10:45 AM	52	29	7	88	1	1	0	2	4	27	31	62	22	19	47	88	240
Total	169	102	37	308	2	4	1	7	18	118	132	268	61	80	166	307	890
11:00 AM	47	23	16	86	0	1	0	1	3	30	30	63	17	29	50	96	246
11:15 AM	49	19	8	76	2	0	0	2	7	29	51	87	15	23	55	93	258
11:30 AM	33	36	16	85	4	2	0	6	3	43	33	79	20	22	52	94	264
11:45 AM	48	21	12	81	4	2	0	6	3	45	27	75	22	35	51	108	270
Total	177	99	52	328	10	5	0	15	16	147	141	304	74	109	208	391	1038
12:00 PM	45	24	16	85	1	0	0	1	14	36	32	82	23	31	43	97	265
12:15 PM	37	17	12	66	0	0	1	1	10	31	50	91	19	25	38	82	240
12:30 PM	37	25	9	71	1	1	0	2	4	28	28	60	23	30	43	96	229
12:45 PM	30	22	10	62	0	2	0	2	6	47	22	75	17	35	68	120	259
Total	149	88	47	284	2	3	1	6	34	142	132	308	82	121	192	395	993
01:00 PM	50	29	10	89	0	0	0	0	5	26	29	60	17	31	53	101	250
01:15 PM	56	20	16	92	0	0	0	0	7	39	31	77	21	27	56	104	273
01:30 PM	40	22	9	71	2	3	0	5	8	37	24	69	25	20	51	96	241
01:45 PM	51	19	7	77	1	2	0	3	6	48	37	91	18	27	45	90	261
Total	197	90	42	329	3	5	0	8	26	150	121	297	81	105	205	391	1025
Grand Total	692	379	178	1249	17	17	2	36	94	557	526	1177	298	415	771	1484	3946
Apprch %	55.4	30.3	14.3		47.2	47.2	5.6		8	47.3	44.7		20.1	28	52		
Total %	17.5	9.6	4.5	31.7	0.4	0.4	0.1	0.9	2.4	14.1	13.3	29.8	7.6	10.5	19.5	37.6	

Massachusetts Department of Transportation

Highway Division

Statewide Traffic Data Collection

Gloucester
 Bass Ave. @ Thatcher & Atlantic Rds.
 Counted by Miovision
 S13-037 TMC # 1

File Name : S13-037 1 Gloucester
 Site Code : 119272
 Start Date : 7/13/2013
 Page No : 1

Groups Printed- Truck

Start Time	Route 127A Thatcher Road From North				Bass Avenue From East				Atlantic Road From South				Route 127A Bass Avenue From West				Int. Total
	Right	Thru	Left	App. Total	Right	Thru	Left	App. Total	Right	Thru	Left	App. Total	Right	Thru	Left	App. Total	
10:00 AM	0	0	0	0	0	0	0	0	0	0	0	0	0	0	1	1	1
10:15 AM	2	0	0	2	0	0	0	0	0	0	1	1	0	1	1	2	5
10:30 AM	0	0	0	0	0	0	0	0	0	1	0	1	0	0	1	1	2
10:45 AM	0	1	0	1	0	0	0	0	0	0	0	0	0	0	0	0	1
Total	2	1	0	3	0	0	0	0	0	1	1	2	0	1	3	4	9
11:00 AM	0	0	1	1	0	0	0	0	0	0	1	1	0	0	0	0	2
11:15 AM	1	0	0	1	0	0	0	0	0	1	1	2	0	0	0	0	3
11:30 AM	0	0	0	0	0	0	0	0	0	0	0	0	0	1	1	2	2
11:45 AM	1	0	1	2	0	0	0	0	0	0	1	1	0	0	0	0	3
Total	2	0	2	4	0	0	0	0	0	1	3	4	0	1	1	2	10
12:00 PM	1	0	0	1	0	0	0	0	0	0	0	0	0	0	0	0	1
12:15 PM	2	1	0	3	0	0	0	0	0	2	0	2	0	1	0	1	6
12:30 PM	2	0	0	2	0	0	0	0	0	0	0	0	0	0	2	2	4
12:45 PM	0	0	0	0	0	0	0	0	0	1	0	1	1	0	0	1	2
Total	5	1	0	6	0	0	0	0	0	3	0	3	1	1	2	4	13
01:00 PM	0	0	1	1	0	0	0	0	0	1	0	1	0	0	1	1	3
01:15 PM	1	0	0	1	0	0	0	0	0	1	0	1	1	0	0	1	3
01:30 PM	1	0	1	2	0	0	0	0	0	0	0	0	0	1	1	2	4
01:45 PM	1	0	0	1	0	0	0	0	0	0	0	0	0	1	0	1	2
Total	3	0	2	5	0	0	0	0	0	2	0	2	1	2	2	5	12
Grand Total	12	2	4	18	0	0	0	0	0	7	4	11	2	5	8	15	44
Apprch %	66.7	11.1	22.2		0	0	0	0	0	63.6	36.4		13.3	33.3	53.3		
Total %	27.3	4.5	9.1	40.9	0	0	0	0	0	15.9	9.1	25	4.5	11.4	18.2	34.1	

Massachusetts Department of Transportation

Highway Division

Statewide Traffic Data Collection

Gloucester
 Bass Ave. @ Thatcher & Atlantic Rds.
 Counted by Miovision
 S13-037 TMC # 1

File Name : S13-037 1 Gloucester
 Site Code : 119272
 Start Date : 7/13/2013
 Page No : 1

Groups Printed- Pedal Bike (Road)

Start Time	Route 127A Thatcher Road From North				Bass Avenue From East				Atlantic Road From South				Route 127A Bass Avenue From West				Int. Total
	Right	Thru	Left	App. Total	Right	Thru	Left	App. Total	Right	Thru	Left	App. Total	Right	Thru	Left	App. Total	
10:00 AM	0	0	0	0	2	0	0	2	0	0	1	1	0	0	2	2	5
10:15 AM	0	0	2	2	0	6	0	6	0	7	0	7	0	1	1	2	17
10:30 AM	0	0	0	0	1	0	0	1	0	18	1	19	0	1	2	3	23
10:45 AM	0	0	1	1	0	0	0	0	0	0	0	0	0	2	5	7	8
Total	0	0	3	3	3	6	0	9	0	25	2	27	0	4	10	14	53
11:00 AM	0	0	1	1	0	0	0	0	0	1	0	1	2	2	0	4	6
11:15 AM	0	0	4	4	0	0	0	0	0	0	0	0	0	0	0	0	4
11:30 AM	0	0	1	1	0	0	0	0	0	0	0	0	0	0	0	0	1
11:45 AM	0	0	3	3	0	0	0	0	0	2	0	2	0	0	0	0	5
Total	0	0	9	9	0	0	0	0	0	3	0	3	2	2	0	4	16
12:15 PM	0	0	1	1	0	0	0	0	0	0	0	0	0	1	1	2	3
12:30 PM	0	1	0	1	0	0	0	0	0	0	0	0	0	0	0	0	1
12:45 PM	1	0	0	1	0	0	0	0	0	0	0	0	0	1	0	1	2
Total	1	1	1	3	0	0	0	0	0	0	0	0	0	2	1	3	6
01:00 PM	0	0	0	0	3	1	0	4	0	0	0	0	0	0	0	0	4
01:15 PM	0	1	0	1	1	2	0	3	0	0	3	3	0	0	6	6	13
01:30 PM	0	0	0	0	0	1	0	1	0	0	0	0	0	0	2	2	3
Total	0	1	0	1	4	4	0	8	0	0	3	3	0	0	8	8	20
Grand Total	1	2	13	16	7	10	0	17	0	28	5	33	2	8	19	29	95
Apprch %	6.2	12.5	81.2		41.2	58.8	0		0	84.8	15.2		6.9	27.6	65.5		
Total %	1.1	2.1	13.7	16.8	7.4	10.5	0	17.9	0	29.5	5.3	34.7	2.1	8.4	20	30.5	

Massachusetts Department of Transportation

Highway Division

Statewide Traffic Data Collection

Gloucester
 Bass Ave. @ Thatcher & Atlantic Rds.
 Counted by Miovision
 S13-037 TMC # 1

File Name : S13-037 1 Gloucester
 Site Code : 119272
 Start Date : 7/13/2013
 Page No : 1

Groups Printed- Ped

Start Time	Route 127A Thatcher Road From North		Bass Avenue From East		Atlantic Road From South		Route 127A Bass Avenue From West		Int. Total
	Peds	App. Total	Peds	App. Total	Peds	App. Total	Peds	App. Total	
10:00 AM	6	6	2	2	1	1	0	0	9
10:15 AM	7	7	0	0	2	2	1	1	10
10:30 AM	1	1	0	0	0	0	1	1	2
10:45 AM	1	1	0	0	1	1	0	0	2
Total	15	15	2	2	4	4	2	2	23
11:00 AM	1	1	0	0	0	0	1	1	2
11:15 AM	6	6	4	4	0	0	1	1	11
11:30 AM	8	8	0	0	0	0	0	0	8
11:45 AM	9	9	2	2	3	3	0	0	14
Total	24	24	6	6	3	3	2	2	35
12:00 PM	3	3	0	0	1	1	0	0	4
12:15 PM	12	12	0	0	0	0	0	0	12
12:30 PM	2	2	0	0	0	0	0	0	2
12:45 PM	1	1	0	0	2	2	0	0	3
Total	18	18	0	0	3	3	0	0	21
01:00 PM	8	8	0	0	0	0	1	1	9
01:15 PM	9	9	0	0	1	1	1	1	11
01:30 PM	16	16	0	0	0	0	0	0	16
01:45 PM	4	4	0	0	0	0	0	0	4
Total	37	37	0	0	1	1	2	2	40
Grand Total	94	94	8	8	11	11	6	6	119
Apprch %	100		100		100		100		
Total %	79	79	6.7	6.7	9.2	9.2	5	5	

Massachusetts Department of Transportation

Highway Division

Statewide Traffic Data Collection

Gloucester
 Thatcher Road (Rte 127A) & Witham Street
 Counted by Miovision
 S13-037 TMC # 3

File Name : S13-037 3 Gloucester
 Site Code : 119286
 Start Date : 7/13/2013
 Page No : 1

Groups Printed- Car - Truck

Start Time	Route 127A From North				Witham Street From East				Route 127A From South				Witham Street From West				Int. Total
	Right	Thru	Left	App. Total	Right	Thru	Left	App. Total	Right	Thru	Left	App. Total	Right	Thru	Left	App. Total	
10:00 AM	5	62	2	69	2	1	3	6	2	57	2	61	8	2	12	22	158
10:15 AM	3	59	1	63	1	1	7	9	6	55	6	67	11	5	5	21	160
10:30 AM	6	56	2	64	1	5	12	18	13	60	9	82	8	4	9	21	185
10:45 AM	4	71	2	77	2	1	13	16	5	52	7	64	7	4	15	26	183
Total	18	248	7	273	6	8	35	49	26	224	24	274	34	15	41	90	686
11:00 AM	6	59	1	66	1	1	7	9	11	57	6	74	4	3	16	23	172
11:15 AM	6	41	0	47	0	0	6	6	6	81	6	93	6	1	9	16	162
11:30 AM	1	57	1	59	0	0	9	9	8	75	8	91	5	1	7	13	172
11:45 AM	5	60	0	65	0	3	6	9	7	83	4	94	6	2	7	15	183
Total	18	217	2	237	1	4	28	33	32	296	24	352	21	7	39	67	689
12:00 PM	2	64	2	68	1	1	9	11	10	64	6	80	13	1	5	19	178
12:15 PM	3	51	2	56	0	1	5	6	7	82	4	93	3	3	2	8	163
12:30 PM	3	55	3	61	1	2	6	9	5	76	9	90	3	1	10	14	174
12:45 PM	6	51	3	60	1	1	7	9	13	83	8	104	1	3	7	11	184
Total	14	221	10	245	3	5	27	35	35	305	27	367	20	8	24	52	699
01:00 PM	1	54	0	55	1	2	2	5	7	89	6	102	5	4	7	16	178
01:15 PM	4	69	1	74	1	3	5	9	14	69	3	86	6	0	3	9	178
01:30 PM	3	70	3	76	2	3	11	16	11	80	9	100	6	4	7	17	209
01:45 PM	4	62	1	67	3	1	9	13	10	88	8	106	8	7	6	21	207
Total	12	255	5	272	7	9	27	43	42	326	26	394	25	15	23	63	772
Grand Total	62	941	24	1027	17	26	117	160	135	1151	101	1387	100	45	127	272	2846
Apprch %	6	91.6	2.3		10.6	16.2	73.1		9.7	83	7.3		36.8	16.5	46.7		
Total %	2.2	33.1	0.8	36.1	0.6	0.9	4.1	5.6	4.7	40.4	3.5	48.7	3.5	1.6	4.5	9.6	
Car	61	938	23	1022	17	26	116	159	135	1144	99	1378	98	45	127	270	2829
% Car	98.4	99.7	95.8	99.5	100	100	99.1	99.4	100	99.4	98	99.4	98	100	100	99.3	99.4
Truck	1	3	1	5	0	0	1	1	0	7	2	9	2	0	0	2	17
% Truck	1.6	0.3	4.2	0.5	0	0	0.9	0.6	0	0.6	2	0.6	2	0	0	0.7	0.6

Massachusetts Department of Transportation
Highway Division
Statewide Traffic Data Collection

File Name : S13-037 3 Gloucester
 Site Code : 119286
 Start Date : 7/13/2013
 Page No : 2

Start Time	Route 127A From North			App. Total	Witham Street From East			App. Total	Route 127A From South			App. Total	Witham Street From West			App. Total	Int. Total
	Right	Thru	Left		Right	Thru	Left		Right	Thru	Left		Right	Thru	Left		
Peak Hour Analysis From 10:00 AM to 01:45 PM - Peak 1 of 1																	
Peak Hour for Entire Intersection Begins at 01:00 PM																	
01:00 PM	1	54	0	55	1	2	2	5	7	89	6	102	5	4	7	16	178
01:15 PM	4	69	1	74	1	3	5	9	14	69	3	86	6	0	3	9	178
01:30 PM	3	70	3	76	2	3	11	16	11	80	9	100	6	4	7	17	209
01:45 PM	4	62	1	67	3	1	9	13	10	88	8	106	8	7	6	21	207
Total Volume	12	255	5	272	7	9	27	43	42	326	26	394	25	15	23	63	772
% App. Total	4.4	93.8	1.8		16.3	20.9	62.8		10.7	82.7	6.6		39.7	23.8	36.5		
PHF	.750	.911	.417	.895	.583	.750	.614	.672	.750	.916	.722	.929	.781	.536	.821	.750	.923

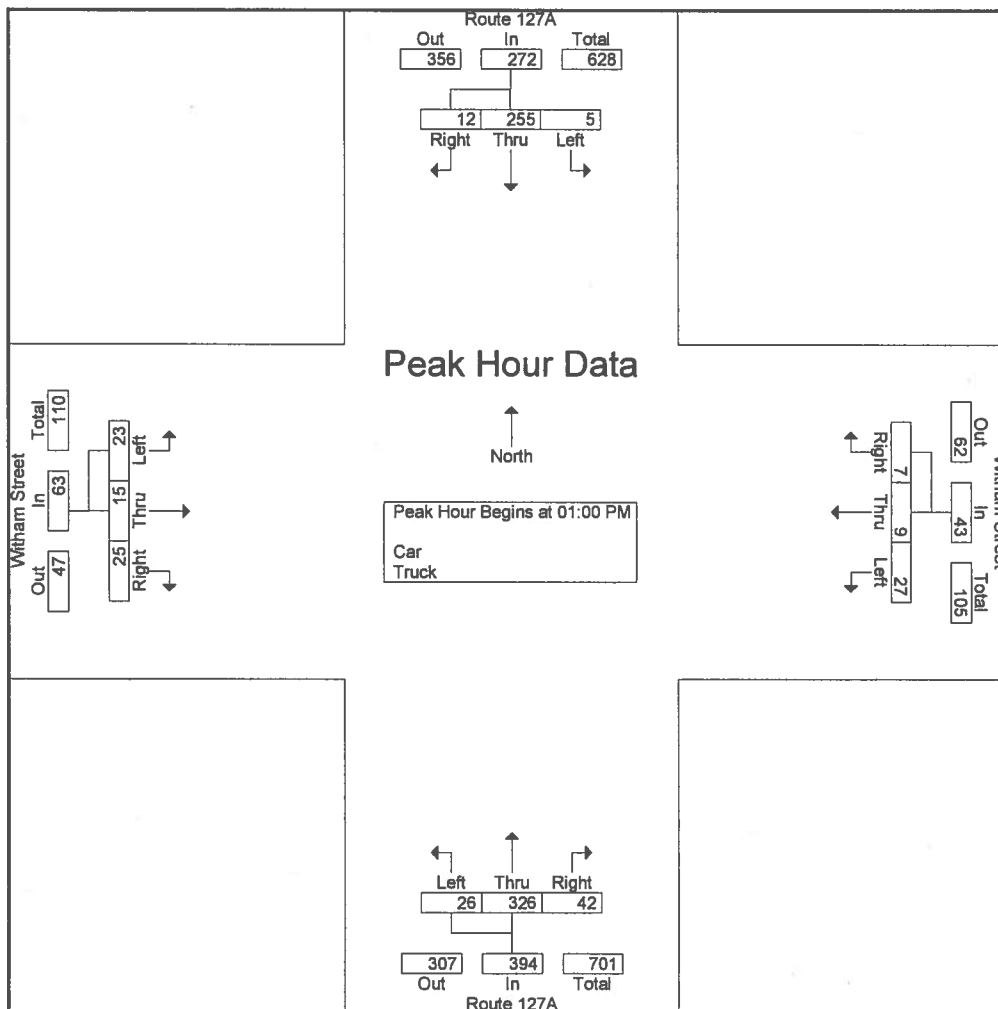

Massachusetts Department of Transportation

Highway Division

Statewide Traffic Data Collection

Gloucester
 Thatcher Road (Rte 127A) & Witham Street
 Counted by Miovision
 S13-037 TMC # 3

File Name : S13-037 3 Gloucester
 Site Code : 119286
 Start Date : 7/13/2013
 Page No : 1

Groups Printed- Car

Start Time	Route 127A From North				Witham Street From East				Route 127A From South				Witham Street From West				Int. Total
	Right	Thru	Left	App. Total	Right	Thru	Left	App. Total	Right	Thru	Left	App. Total	Right	Thru	Left	App. Total	
10:00 AM	5	62	2	69	2	1	3	6	2	56	2	60	8	2	12	22	157
10:15 AM	3	59	1	63	1	1	7	9	6	55	5	66	11	5	5	21	159
10:30 AM	6	56	2	64	1	5	12	18	13	60	9	82	8	4	9	21	185
10:45 AM	4	70	2	76	2	1	13	16	5	51	7	63	7	4	15	26	181
Total	18	247	7	272	6	8	35	49	26	222	23	271	34	15	41	90	682
11:00 AM	6	58	1	65	1	1	7	9	11	57	6	74	4	3	16	23	171
11:15 AM	6	41	0	47	0	0	6	6	6	81	6	93	6	1	9	16	162
11:30 AM	1	57	1	59	0	0	9	9	8	75	8	91	5	1	7	13	172
11:45 AM	5	60	0	65	0	3	6	9	7	83	4	94	6	2	7	15	183
Total	18	216	2	236	1	4	28	33	32	296	24	352	21	7	39	67	688
12:00 PM	2	64	2	68	1	1	9	11	10	63	6	79	13	1	5	19	177
12:15 PM	3	51	2	56	0	1	4	5	7	82	3	92	3	3	2	8	161
12:30 PM	3	55	2	60	1	2	6	9	5	76	9	90	2	1	10	13	172
12:45 PM	6	51	3	60	1	1	7	9	13	82	8	103	1	3	7	11	183
Total	14	221	9	244	3	5	26	34	35	303	26	364	19	8	24	51	693
01:00 PM	1	53	0	54	1	2	2	5	7	88	6	101	5	4	7	16	176
01:15 PM	4	69	1	74	1	3	5	9	14	69	3	86	6	0	3	9	178
01:30 PM	2	70	3	75	2	3	11	16	11	78	9	98	5	4	7	16	205
01:45 PM	4	62	1	67	3	1	9	13	10	88	8	106	8	7	6	21	207
Total	11	254	5	270	7	9	27	43	42	323	26	391	24	15	23	62	766
Grand Total	61	938	23	1022	17	26	116	159	135	1144	99	1378	98	45	127	270	2829
Apprch %	6	91.8	2.3		10.7	16.4	73		9.8	83	7.2		36.3	16.7	47		
Total %	2.2	33.2	0.8	36.1	0.6	0.9	4.1	5.6	4.8	40.4	3.5	48.7	3.5	1.6	4.5	9.5	

Massachusetts Department of Transportation

Highway Division

Statewide Traffic Data Collection

Gloucester
 Thatcher Road (Rte 127A) & Witham Street
 Counted by Miovision
 S13-037 TMC # 3

File Name : S13-037 3 Gloucester
 Site Code : 119286
 Start Date : 7/13/2013
 Page No : 1

Groups Printed- Truck

Start Time	Route 127A From North				Witham Street From East				Route 127A From South				Witham Street From West				Int. Total
	Right	Thru	Left	App. Total	Right	Thru	Left	App. Total	Right	Thru	Left	App. Total	Right	Thru	Left	App. Total	
10:00 AM	0	0	0	0	0	0	0	0	0	1	0	1	0	0	0	0	0
10:15 AM	0	0	0	0	0	0	0	0	0	0	1	1	0	0	0	0	0
10:45 AM	0	1	0	1	0	0	0	0	0	1	0	1	0	0	0	0	0
Total	0	1	0	1	0	0	0	0	0	2	1	3	0	0	0	0	0
11:00 AM	0	1	0	1	0	0	0	0	0	0	0	0	0	0	0	0	0
Total	0	1	0	1	0	0	0	0	0	0	0	0	0	0	0	0	0
12:00 PM	0	0	0	0	0	0	0	0	0	1	0	1	0	0	0	0	0
12:15 PM	0	0	0	0	0	0	1	1	0	0	1	1	0	0	0	0	0
12:30 PM	0	0	1	1	0	0	0	0	0	0	0	0	1	0	0	1	1
12:45 PM	0	0	0	0	0	0	0	0	0	1	0	1	0	0	0	0	0
Total	0	0	1	1	0	0	1	1	0	2	1	3	1	0	0	1	1
01:00 PM	0	1	0	1	0	0	0	0	0	1	0	1	0	0	0	0	0
01:30 PM	1	0	0	1	0	0	0	0	0	2	0	2	1	0	0	1	1
Total	1	1	0	2	0	0	0	0	0	3	0	3	1	0	0	1	1
Grand Total	1	3	1	5	0	0	1	1	0	7	2	9	2	0	0	2	17
Apprch %	20	60	20		0	0	100		0	77.8	22.2		100	0	0		
Total %	5.9	17.6	5.9	29.4	0	0	5.9	5.9	0	41.2	11.8	52.9	11.8	0	0	11.8	

Massachusetts Department of Transportation

Highway Division

Statewide Traffic Data Collection

Gloucester
 Thatcher Road (Rte 127A) & Witham Street
 Counted by Miovision
 S13-037 TMC # 3

File Name : S13-037 3 Gloucester
 Site Code : 119286
 Start Date : 7/13/2013
 Page No : 1

Groups Printed- Pedal Bike (Road)

Start Time	Route 127A From North				Witham Street From East				Route 127A From South				Witham Street From West				Int. Total
	Right	Thru	Left	App. Total	Right	Thru	Left	App. Total	Right	Thru	Left	App. Total	Right	Thru	Left	App. Total	
10:00 AM	0	1	0	1	0	0	0	0	0	3	0	3	0	0	0	0	4
10:15 AM	0	1	0	1	0	0	0	0	0	6	0	6	0	0	0	0	7
10:30 AM	0	0	0	0	0	0	0	0	0	26	0	26	0	0	0	0	26
10:45 AM	0	1	0	1	2	0	0	2	0	4	1	5	0	0	0	0	8
Total	0	3	0	3	2	0	0	2	0	39	1	40	0	0	0	0	45
11:00 AM	0	0	0	0	0	0	0	0	0	2	0	2	1	0	0	1	3
11:15 AM	0	2	0	2	0	0	0	0	0	0	0	0	0	0	0	0	2
11:30 AM	0	1	0	1	0	0	1	1	0	3	0	3	0	0	0	0	5
11:45 AM	0	1	0	1	0	0	0	0	0	1	0	1	0	0	0	0	2
Total	0	4	0	4	0	0	1	1	0	6	0	6	1	0	0	1	12
12:00 PM	0	2	0	2	0	0	0	0	0	0	0	0	0	0	1	1	3
12:30 PM	0	3	0	3	0	0	0	0	0	1	0	1	0	0	0	0	4
12:45 PM	0	1	0	1	0	1	0	1	0	1	0	1	0	0	0	0	3
Total	0	6	0	6	0	1	0	1	0	2	0	2	0	0	1	1	10
01:00 PM	0	0	0	0	0	0	0	0	0	2	0	2	0	0	0	0	2
01:15 PM	0	1	0	1	0	0	0	0	0	2	0	2	0	0	0	0	3
01:30 PM	0	2	0	2	0	0	0	0	0	5	0	5	0	0	0	0	7
01:45 PM	0	2	0	2	0	0	0	0	0	3	0	3	0	0	1	1	6
Total	0	5	0	5	0	0	0	0	0	12	0	12	0	0	1	1	18
Grand Total	0	18	0	18	2	1	1	4	0	59	1	60	1	0	2	3	85
Apprch %	0	100	0		50	25	25		0	98.3	1.7		33.3	0	66.7		
Total %	0	21.2	0	21.2	2.4	1.2	1.2	4.7	0	69.4	1.2	70.6	1.2	0	2.4	3.5	

Massachusetts Department of Transportation

Highway Division

Statewide Traffic Data Collection

Gloucester
 Thatcher Road (Rte 127A) & Witham Street
 Counted by Miovision
 S13-037 TMC # 3

File Name : S13-037 3 Gloucester
 Site Code : 119286
 Start Date : 7/13/2013
 Page No : 1

Groups Printed- Ped

Start Time	Route 127A From North		Witham Street From East		Route 127A From South		Witham Street From West		Int. Total
	Peds	App. Total	Peds	App. Total	Peds	App. Total	Peds	App. Total	
10:15 AM	2	2	0	0	0	0	0	0	2
10:30 AM	5	5	0	0	1	1	0	0	6
10:45 AM	4	4	0	0	0	0	0	0	4
Total	11	11	0	0	1	1	0	0	12
11:00 AM	3	3	0	0	0	0	0	0	3
11:15 AM	0	0	0	0	0	0	1	1	1
11:30 AM	2	2	0	0	0	0	0	0	2
11:45 AM	3	3	0	0	0	0	0	0	3
Total	8	8	0	0	0	0	1	1	9
12:00 PM	1	1	0	0	0	0	0	0	1
12:15 PM	3	3	0	0	0	0	0	0	3
12:30 PM	2	2	0	0	0	0	0	0	2
12:45 PM	1	1	0	0	0	0	0	0	1
Total	7	7	0	0	0	0	0	0	7
01:00 PM	2	2	0	0	0	0	0	0	2
01:15 PM	6	6	0	0	0	0	2	2	8
01:30 PM	7	7	0	0	0	0	0	0	7
01:45 PM	6	6	0	0	0	0	1	1	7
Total	21	21	0	0	0	0	3	3	24
Grand Total	47	47	0	0	1	1	4	4	52
Apprch %	100		0		100		100		
Total %	90.4	90.4	0	0	1.9	1.9	7.7	7.7	

Massachusetts Department of Transportation

Highway Division

Statewide Traffic Data Collection

Rockport
 Mt Pleasant St & Broadway & T-Wharf
 Counted by Miovision
 S13-037 TMC # 4

File Name : S13-037 4 Rockport
 Site Code : 119287
 Start Date : 7/13/2013
 Page No : 1

Groups Printed- Car - Truck

Start Time	From North	T-Wharf From East			Route 127A Mt Pleasant Street From South				Route 127A Broadway From West				Int. Total	
	App. Total	Right	Thru	Left	App. Total	Right	Thru	Left	App. Total	Right	Thru	Left		App. Total
10:00 AM	0	3	5	6	14	1	34	47	82	47	8	50	105	201
10:15 AM	0	6	2	5	13	8	44	41	93	55	8	39	102	208
10:30 AM	0	12	2	2	16	4	27	50	81	62	10	38	110	207
10:45 AM	0	4	2	6	12	10	36	38	84	52	8	33	93	189
Total	0	25	11	19	55	23	141	176	340	216	34	160	410	805
11:00 AM	0	8	4	1	13	5	33	41	79	71	5	45	121	213
11:15 AM	0	9	3	6	18	9	37	39	85	62	11	46	119	222
11:30 AM	0	8	4	5	17	8	43	49	100	48	17	36	101	218
11:45 AM	0	10	8	8	26	6	40	55	101	69	11	39	119	246
Total	0	35	19	20	74	28	153	184	365	250	44	166	460	899
12:00 PM	0	3	6	6	15	5	39	40	84	72	16	42	130	229
12:15 PM	0	5	4	6	15	4	33	44	81	68	13	38	119	215
12:30 PM	0	6	4	2	12	6	46	31	83	56	9	35	100	195
12:45 PM	0	7	2	7	16	15	34	44	93	63	9	50	122	231
Total	0	21	16	21	58	30	152	159	341	259	47	165	471	870
01:00 PM	0	11	5	3	19	5	47	39	91	61	9	47	117	227
01:15 PM	0	13	4	6	23	7	34	44	85	67	13	42	122	230
01:30 PM	0	12	5	5	22	4	38	43	85	57	10	36	103	210
01:45 PM	0	8	4	7	19	6	41	44	91	47	8	45	100	210
Total	0	44	18	21	83	22	160	170	352	232	40	170	442	877
Grand Total	0	125	64	81	270	103	606	689	1398	957	165	661	1783	3451
Apprch %		46.3	23.7	30		7.4	43.3	49.3		53.7	9.3	37.1		
Total %	0	3.6	1.9	2.3	7.8	3	17.6	20	40.5	27.7	4.8	19.2	51.7	
Car	0	124	64	81	269	102	601	681	1384	952	165	646	1763	3416
% Car	0	99.2	100	100	99.6	99	99.2	98.8	99	99.5	100	97.7	98.9	99
Truck	0	1	0	0	1	1	5	8	14	5	0	15	20	35
% Truck	0	0.8	0	0	0.4	1	0.8	1.2	1	0.5	0	2.3	1.1	1

Massachusetts Department of Transportation
Highway Division
Statewide Traffic Data Collection

File Name : S13-037 4 Rockport
 Site Code : 119287
 Start Date : 7/13/2013
 Page No : 2

Start Time	From North	T-Wharf From East			Route 127A Mt Pleasant Street From South				Route 127A Broadway From West				Int. Total	
	App. Total	Right	Thru	Left	App. Total	Right	Thru	Left	App. Total	Right	Thru	Left		App. Total
Peak Hour Analysis From 10:00 AM to 01:45 PM - Peak 1 of 1														
Peak Hour for Entire Intersection Begins at 11:15 AM														
11:15 AM	0	9	3	6	18	9	37	39	85	62	11	46	119	222
11:30 AM	0	8	4	5	17	8	43	49	100	48	17	36	101	218
11:45 AM	0	10	8	8	26	6	40	55	101	69	11	39	119	246
12:00 PM	0	3	6	6	15	5	39	40	84	72	16	42	130	229
Total Volume	0	30	21	25	76	28	159	183	370	251	55	163	469	915
% App. Total		39.5	27.6	32.9		7.6	43	49.5		53.5	11.7	34.8		
PHF	.000	.750	.656	.781	.731	.778	.924	.832	.916	.872	.809	.886	.902	.930

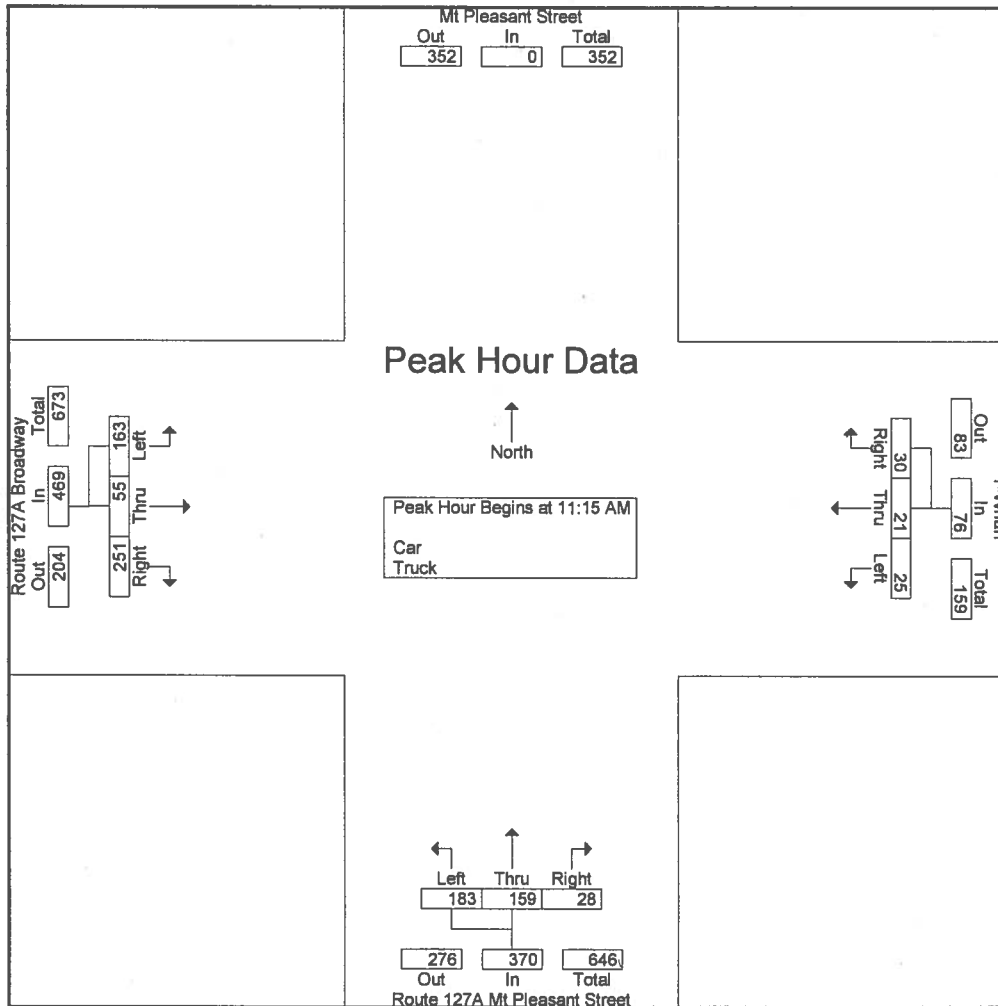

Massachusetts Department of Transportation

Highway Division

Statewide Traffic Data Collection

Rockport
 Mt Pleasant St & Broadway & T-Wharf
 Counted by Miovision
 S13-037 TMC # 4

File Name : S13-037 4 Rockport
 Site Code : 119287
 Start Date : 7/13/2013
 Page No : 1

Groups Printed- Car

Start Time	From North	T-Wharf From East			Route 127A Mt Pleasant Street From South				Route 127A Broadway From West				Int. Total	
	App. Total	Right	Thru	Left	App. Total	Right	Thru	Left	App. Total	Right	Thru	Left		App. Total
10:00 AM	0	3	5	6	14	1	34	47	82	47	8	49	104	200
10:15 AM	0	6	2	5	13	7	44	40	91	54	8	39	101	205
10:30 AM	0	11	2	2	15	4	27	50	81	61	10	37	108	204
10:45 AM	0	4	2	6	12	10	35	37	82	50	8	33	91	185
Total	0	24	11	19	54	22	140	174	336	212	34	158	404	794
11:00 AM	0	8	4	1	13	5	33	41	79	71	5	45	121	213
11:15 AM	0	9	3	6	18	9	37	36	82	62	11	44	117	217
11:30 AM	0	8	4	5	17	8	43	48	99	48	17	35	100	216
11:45 AM	0	10	8	8	26	6	40	55	101	69	11	38	118	245
Total	0	35	19	20	74	28	153	180	361	250	44	162	456	891
12:00 PM	0	3	6	6	15	5	39	40	84	72	16	39	127	226
12:15 PM	0	5	4	6	15	4	33	44	81	68	13	37	118	214
12:30 PM	0	6	4	2	12	6	45	31	82	56	9	34	99	193
12:45 PM	0	7	2	7	16	15	33	44	92	62	9	50	121	229
Total	0	21	16	21	58	30	150	159	339	258	47	160	465	862
01:00 PM	0	11	5	3	19	5	47	38	90	61	9	47	117	226
01:15 PM	0	13	4	6	23	7	34	44	85	67	13	41	121	229
01:30 PM	0	12	5	5	22	4	37	42	83	57	10	35	102	207
01:45 PM	0	8	4	7	19	6	40	44	90	47	8	43	98	207
Total	0	44	18	21	83	22	158	168	348	232	40	166	438	869
Grand Total	0	124	64	81	269	102	601	681	1384	952	165	646	1763	3416
Apprch %		46.1	23.8	30.1		7.4	43.4	49.2		54	9.4	36.6		
Total %	0	3.6	1.9	2.4	7.9	3	17.6	19.9	40.5	27.9	4.8	18.9	51.6	

Massachusetts Department of Transportation

Highway Division

Statewide Traffic Data Collection

Rockport
 Mt Pleasant St & Broadway & T-Wharf
 Counted by Miovision
 S13-037 TMC # 4

File Name : S13-037 4 Rockport
 Site Code : 119287
 Start Date : 7/13/2013
 Page No : 1

Groups Printed- Truck

Start Time	From North	T-Wharf From East			Route 127A Mt Pleasant Street From South				Route 127A Broadway From West				Int. Total	
	App. Total	Right	Thru	Left	App. Total	Right	Thru	Left	App. Total	Right	Thru	Left		App. Total
10:00 AM	0	0	0	0	0	0	0	0	0	0	0	1	1	1
10:15 AM	0	0	0	0	0	1	0	1	2	1	0	0	1	3
10:30 AM	0	1	0	0	1	0	0	0	0	1	0	1	2	3
10:45 AM	0	0	0	0	0	0	1	1	2	2	0	0	2	4
Total	0	1	0	0	1	1	1	2	4	4	0	2	6	11
11:15 AM	0	0	0	0	0	0	0	3	3	0	0	2	2	5
11:30 AM	0	0	0	0	0	0	0	1	1	0	0	1	1	2
11:45 AM	0	0	0	0	0	0	0	0	0	0	0	1	1	1
Total	0	0	0	0	0	0	0	4	4	0	0	4	4	8
12:00 PM	0	0	0	0	0	0	0	0	0	0	0	3	3	3
12:15 PM	0	0	0	0	0	0	0	0	0	0	0	1	1	1
12:30 PM	0	0	0	0	0	0	1	0	1	0	0	1	1	2
12:45 PM	0	0	0	0	0	0	1	0	1	1	0	0	1	2
Total	0	0	0	0	0	0	2	0	2	1	0	5	6	8
01:00 PM	0	0	0	0	0	0	0	1	1	0	0	0	0	1
01:15 PM	0	0	0	0	0	0	0	0	0	0	0	1	1	1
01:30 PM	0	0	0	0	0	0	1	1	2	0	0	1	1	3
01:45 PM	0	0	0	0	0	0	1	0	1	0	0	2	2	3
Total	0	0	0	0	0	0	2	2	4	0	0	4	4	8
Grand Total	0	1	0	0	1	1	5	8	14	5	0	15	20	35
Apprch %		100	0	0		7.1	35.7	57.1		25	0	75		
Total %	0	2.9	0	0	2.9	2.9	14.3	22.9	40	14.3	0	42.9	57.1	

Massachusetts Department of Transportation

Highway Division

Statewide Traffic Data Collection

Rockport
 Mt Pleasant St & Broadway & T-Wharf
 Counted by Miovision
 S13-037 TMC # 4

File Name : S13-037 4 Rockport
 Site Code : 119287
 Start Date : 7/13/2013
 Page No : 1

Groups Printed- Pedal Bike (Road)

Start Time	From North	T-Wharf From East			Route 127A Mt Pleasant Street From South				Route 127A Broadway From West				Int. Total	
	App. Total	Right	Thru	Left	App. Total	Right	Thru	Left	App. Total	Right	Thru	Left		App. Total
10:00 AM	0	1	0	0	1	0	0	1	1	0	0	0	0	2
10:15 AM	0	1	0	0	1	0	2	2	4	0	0	0	0	5
10:30 AM	0	0	0	0	0	0	9	0	9	0	0	2	2	11
10:45 AM	0	0	0	0	0	0	17	0	17	0	1	0	1	18
Total	0	2	0	0	2	0	28	3	31	0	1	2	3	36
11:00 AM	0	0	0	0	0	0	3	2	5	0	1	0	1	6
11:15 AM	0	0	0	0	0	0	1	0	1	0	0	0	0	1
11:30 AM	0	0	0	0	0	0	3	0	3	0	1	0	1	4
11:45 AM	0	0	0	0	0	0	6	0	6	0	0	0	0	6
Total	0	0	0	0	0	0	13	2	15	0	2	0	2	17
12:00 PM	0	0	0	0	0	3	1	0	4	0	0	0	0	4
12:15 PM	0	3	0	0	3	0	2	0	2	0	1	5	6	11
12:45 PM	0	0	0	0	0	2	2	0	4	1	1	0	2	6
Total	0	3	0	0	3	5	5	0	10	1	2	5	8	21
01:00 PM	0	0	0	0	0	0	2	1	3	0	1	0	1	4
01:15 PM	0	0	0	0	0	0	1	0	1	0	0	0	0	1
01:30 PM	0	0	0	0	0	0	2	0	2	0	0	0	0	2
01:45 PM	0	2	0	0	2	0	1	0	1	0	0	0	0	3
Total	0	2	0	0	2	0	6	1	7	0	1	0	1	10
Grand Total	0	7	0	0	7	5	52	6	63	1	6	7	14	84
Apprch %		100	0	0		7.9	82.5	9.5		7.1	42.9	50		
Total %	0	8.3	0	0	8.3	6	61.9	7.1	75	1.2	7.1	8.3	16.7	

Massachusetts Department of Transportation

Highway Division

Statewide Traffic Data Collection

Rockport
 Mt Pleasant St & Broadway & T-Wharf
 Counted by Miovision
 S13-037 TMC # 4

File Name : S13-037 4 Rockport
 Site Code : 119287
 Start Date : 7/13/2013
 Page No : 1

Groups Printed- Ped

Start Time	Mt Pleasant Street From North		T-Wharf From East		Route 127A Mt Pleasant Street From South		Route 127A Broadway From West		Int. Total
	Peds	App. Total	Peds	App. Total	Peds	App. Total	Peds	App. Total	
10:00 AM	8	8	64	64	48	48	51	51	171
10:15 AM	2	2	62	62	75	75	40	40	179
10:30 AM	4	4	72	72	67	67	53	53	196
10:45 AM	7	7	71	71	59	59	45	45	182
Total	21	21	269	269	249	249	189	189	728
11:00 AM	3	3	84	84	22	22	29	29	138
11:15 AM	6	6	46	46	52	52	52	52	156
11:30 AM	4	4	65	65	41	41	63	63	173
11:45 AM	9	9	80	80	68	68	73	73	230
Total	22	22	275	275	183	183	217	217	697
12:00 PM	37	37	94	94	84	84	38	38	253
12:15 PM	36	36	100	100	82	82	53	53	271
12:30 PM	37	37	83	83	68	68	47	47	235
12:45 PM	23	23	91	91	52	52	49	49	215
Total	133	133	368	368	286	286	187	187	974
01:00 PM	8	8	90	90	44	44	15	15	157
01:15 PM	10	10	96	96	48	48	39	39	193
01:30 PM	6	6	113	113	43	43	33	33	195
01:45 PM	15	15	72	72	46	46	34	34	167
Total	39	39	371	371	181	181	121	121	712
Grand Total	215	215	1283	1283	899	899	714	714	3111
Apprch %	100		100		100		100		
Total %	6.9	6.9	41.2	41.2	28.9	28.9	23	23	

Massachusetts Department of Transportation

Highway Division

Statewide Traffic Data Collection

Rockport
 Mt Pleasant & Main St & Bearskin Neck
 Counted by Miovision
 S13-037 TMC # 5

File Name : S13-037 5 Rockport
 Site Code : 119307
 Start Date : 7/13/2013
 Page No : 1

Groups Printed- Car - Truck

Start Time	From North	Bearskin Neck		Mt Pleasant Street			Int. Total
	App. Total	Right	App. Total	Right	Thru	App. Total	
10:00 AM	0	10	10	21	68	89	99
10:15 AM	0	15	15	15	65	80	95
10:30 AM	0	11	11	17	62	79	90
10:45 AM	0	15	15	14	59	73	88
Total	0	51	51	67	254	321	372
11:00 AM	0	11	11	17	64	81	92
11:15 AM	0	16	16	17	65	82	98
11:30 AM	0	8	8	10	69	79	87
11:45 AM	0	12	12	11	66	77	89
Total	0	47	47	55	264	319	366
12:00 PM	0	7	7	12	75	87	94
12:15 PM	0	15	15	9	63	72	87
12:30 PM	0	8	8	5	81	86	94
12:45 PM	0	9	9	7	88	95	104
Total	0	39	39	33	307	340	379
01:00 PM	0	10	10	13	91	104	114
01:15 PM	0	9	9	13	79	92	101
01:30 PM	0	11	11	3	89	92	103
01:45 PM	0	5	5	10	76	86	91
Total	0	35	35	39	335	374	409
Grand Total	0	172	172	194	1160	1354	1526
Apprch %		100		14.3	85.7		
Total %	0	11.3	11.3	12.7	76	88.7	
Car	0	170	170	192	1137	1329	1499
% Car	0	98.8	98.8	99	98	98.2	98.2
Truck	0	2	2	2	23	25	27
% Truck	0	1.2	1.2	1	2	1.8	1.8

Massachusetts Department of Transportation

Highway Division

Statewide Traffic Data Collection

File Name : S13-037 5 Rockport

Site Code : 119307

Start Date : 7/13/2013

Page No : 2

Start Time	From North	Bearskin Neck From East		Mt Pleasant Street From South			Int. Total
	App. Total	Right	App. Total	Right	Thru	App. Total	
Peak Hour Analysis From 10:00 AM to 01:45 PM - Peak 1 of 1							
Peak Hour for Entire Intersection Begins at 12:45 PM							
12:45 PM	0	9	9	7	88	95	104
01:00 PM	0	10	10	13	91	104	114
01:15 PM	0	9	9	13	79	92	101
01:30 PM	0	11	11	3	89	92	103
Total Volume	0	39	39	36	347	383	422
% App. Total		100		9.4	90.6		
PHF	.000	.886	.886	.692	.953	.921	.925

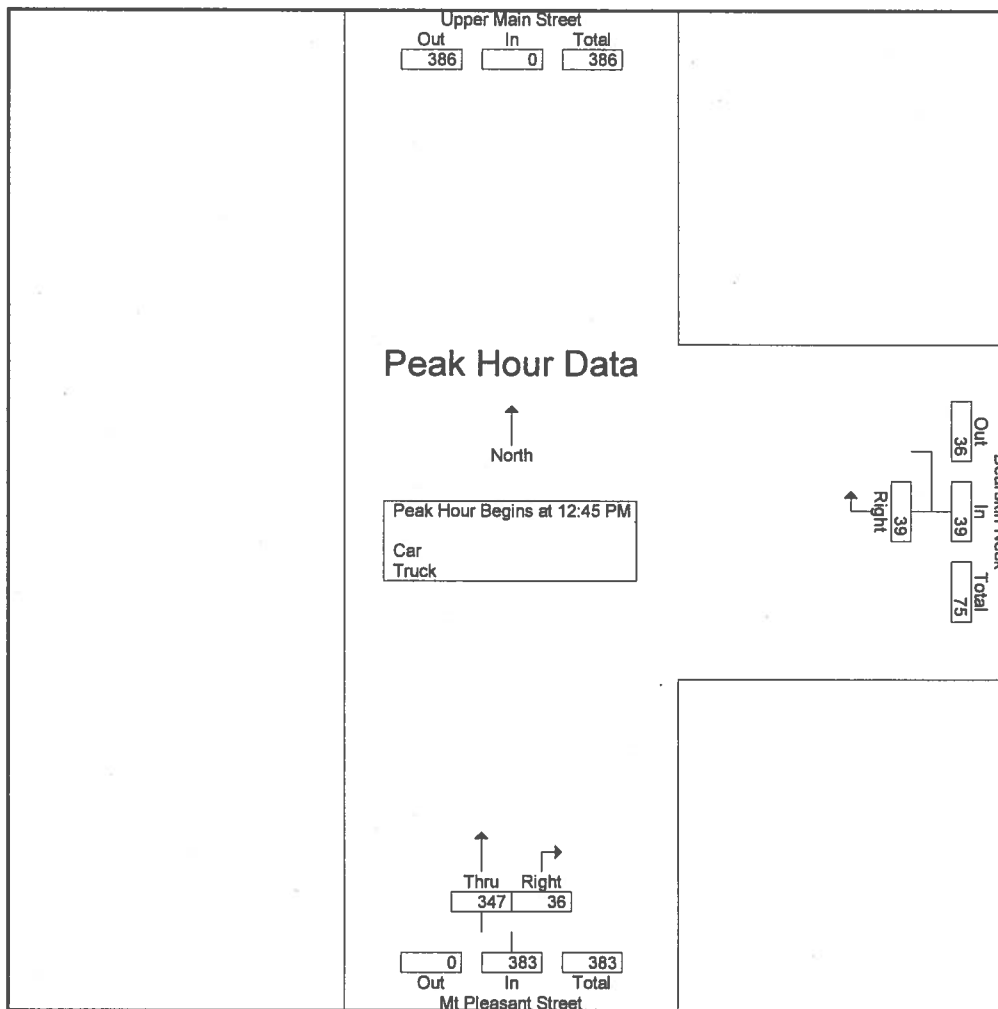

Massachusetts Department of Transportation

Highway Division

Statewide Traffic Data Collection

Rockport
 Mt Pleasant & Main St & Bearskin Neck
 Counted by Miovision
 S13-037 TMC # 5

File Name : S13-037 5 Rockport
 Site Code : 119307
 Start Date : 7/13/2013
 Page No : 1

Groups Printed- Car

Start Time	From North	Bearskin Neck From East		Mt Pleasant Street From South			Int. Total
	App. Total	Right	App. Total	Right	Thru	App. Total	
10:00 AM	0	10	10	21	67	88	98
10:15 AM	0	15	15	15	65	80	95
10:30 AM	0	11	11	16	61	77	88
10:45 AM	0	15	15	14	59	73	88
Total	0	51	51	66	252	318	369
11:00 AM	0	11	11	17	63	80	91
11:15 AM	0	15	15	17	63	80	95
11:30 AM	0	8	8	10	68	78	86
11:45 AM	0	12	12	11	66	77	89
Total	0	46	46	55	260	315	361
12:00 PM	0	7	7	11	72	83	90
12:15 PM	0	15	15	9	62	71	86
12:30 PM	0	8	8	5	79	84	92
12:45 PM	0	8	8	7	85	92	100
Total	0	38	38	32	298	330	368
01:00 PM	0	10	10	13	90	103	113
01:15 PM	0	9	9	13	76	89	98
01:30 PM	0	11	11	3	87	90	101
01:45 PM	0	5	5	10	74	84	89
Total	0	35	35	39	327	366	401
Grand Total	0	170	170	192	1137	1329	1499
Apprch %		100		14.4	85.6		
Total %	0	11.3	11.3	12.8	75.9	88.7	

Massachusetts Department of Transportation

Highway Division

Statewide Traffic Data Collection

Rockport
 Mt Pleasant & Main St & Bearskin Neck
 Counted by Miovision
 S13-037 TMC # 5

File Name : S13-037 5 Rockport
 Site Code : 119307
 Start Date : 7/13/2013
 Page No : 1

Groups Printed- Truck

Start Time	From North	Bearskin Neck		Mt Pleasant Street			Int. Total
	App. Total	From East	App. Total	Right	Thru	App. Total	
10:00 AM	0	0	0	0	1	1	1
10:30 AM	0	0	0	1	1	2	2
Total	0	0	0	1	2	3	3
11:00 AM	0	0	0	0	1	1	1
11:15 AM	0	1	1	0	2	2	3
11:30 AM	0	0	0	0	1	1	1
Total	0	1	1	0	4	4	5
12:00 PM	0	0	0	1	3	4	4
12:15 PM	0	0	0	0	1	1	1
12:30 PM	0	0	0	0	2	2	2
12:45 PM	0	1	1	0	3	3	4
Total	0	1	1	1	9	10	11
01:00 PM	0	0	0	0	1	1	1
01:15 PM	0	0	0	0	3	3	3
01:30 PM	0	0	0	0	2	2	2
01:45 PM	0	0	0	0	2	2	2
Total	0	0	0	0	8	8	8
Grand Total	0	2	2	2	23	25	27
Apprch %		100		8	92		
Total %	0	7.4	7.4	7.4	85.2	92.6	

Massachusetts Department of Transportation

Highway Division

Statewide Traffic Data Collection

Rockport
 Mt Pleasant & Main St & Bearskin Neck
 Counted by Miovision
 S13-037 TMC # 5

File Name : S13-037 5 Rockport
 Site Code : 119307
 Start Date : 7/13/2013
 Page No : 1

Groups Printed- Pedal Bike (Road)

Start Time	From North	Bearskin Neck From East		Mt Pleasant Street From South			Int. Total
	App. Total	Right	App. Total	Right	Thru	App. Total	
10:00 AM	0	2	2	0	0	0	2
10:15 AM	0	0	0	4	0	4	4
10:30 AM	0	3	3	0	7	7	10
10:45 AM	0	0	0	13	1	14	14
Total	0	5	5	17	8	25	30
11:00 AM	0	3	3	2	1	3	6
11:15 AM	0	17	17	3	0	3	20
11:30 AM	0	1	1	2	0	2	3
11:45 AM	0	1	1	6	0	6	7
Total	0	22	22	13	1	14	36
12:00 PM	0	0	0	2	1	3	3
12:15 PM	0	0	0	3	3	6	6
12:45 PM	0	0	0	2	2	4	4
Total	0	0	0	7	6	13	13
01:15 PM	0	2	2	0	1	1	3
Total	0	2	2	0	1	1	3
Grand Total	0	29	29	37	16	53	82
Apprch %		100		69.8	30.2		
Total %	0	35.4	35.4	45.1	19.5	64.6	

Massachusetts Department of Transportation

Highway Division

Statewide Traffic Data Collection

Rockport
 Mt Pleasant & Main St & Bearskin Neck
 Counted by Miovision
 S13-037 TMC # 5

File Name : S13-037 5 Rockport
 Site Code : 119307
 Start Date : 7/13/2013
 Page No : 1

Groups Printed- Ped

Start Time	Upper Main Street From North		Bearskin Neck From East		Mt Pleasant Street From South		Int. Total
	Peds	App. Total	Peds	App. Total	Peds	App. Total	
10:00 AM	5	5	11	11	11	11	27
10:15 AM	0	0	23	23	29	29	52
10:30 AM	6	6	17	17	8	8	31
10:45 AM	4	4	15	15	7	7	26
Total	15	15	66	66	55	55	136
11:00 AM	9	9	28	28	20	20	57
11:15 AM	7	7	23	23	27	27	57
11:30 AM	10	10	54	54	20	20	84
11:45 AM	5	5	44	44	38	38	87
Total	31	31	149	149	105	105	285
12:00 PM	1	1	50	50	25	25	76
12:15 PM	17	17	57	57	17	17	91
12:30 PM	10	10	47	47	32	32	89
12:45 PM	6	6	62	62	38	38	106
Total	34	34	216	216	112	112	362
01:00 PM	10	10	33	33	65	65	108
01:15 PM	10	10	67	67	57	57	134
01:30 PM	7	7	53	53	55	55	115
01:45 PM	13	13	55	55	38	38	106
Total	40	40	208	208	215	215	463
Grand Total	120	120	639	639	487	487	1246
Apprch %	100		100		100		
Total %	9.6	9.6	51.3	51.3	39.1	39.1	

Massachusetts Department of Transportation

Highway Division

Statewide Traffic Data Collection

Gloucester
 Rte 127(Washington St) & Stanwood Street
 Counted by Miovision
 S13-037 TMC # 6

File Name : S13-037 6 Gloucester
 Site Code : 119308
 Start Date : 7/13/2013
 Page No : 1

Groups Printed- Car - Truck

Start Time	Route 127 Washington Street From North			Stanwood Street From East			Route 127 Washington Street From South			Int. Total
	Thru	Left	App. Total	Right	Left	App. Total	Right	Thru	App. Total	
10:00 AM	87	13	100	13	0	13	0	66	66	179
10:15 AM	102	14	116	13	2	15	2	74	76	207
10:30 AM	91	8	99	9	5	14	3	60	63	176
10:45 AM	86	3	89	9	3	12	2	86	88	189
Total	366	38	404	44	10	54	7	286	293	751
11:00 AM	89	7	96	14	2	16	1	81	82	194
11:15 AM	74	7	81	14	3	17	1	88	89	187
11:30 AM	90	22	112	14	3	17	3	98	101	230
11:45 AM	82	8	90	17	3	20	3	73	76	186
Total	335	44	379	59	11	70	8	340	348	797
12:00 PM	92	7	99	13	1	14	2	93	95	208
12:15 PM	73	11	84	10	0	10	2	100	102	196
12:30 PM	64	4	68	18	1	19	1	89	90	177
12:45 PM	67	6	73	14	2	16	1	112	113	202
Total	296	28	324	55	4	59	6	394	400	783
01:00 PM	80	13	93	16	2	18	0	74	74	185
01:15 PM	81	12	93	6	3	9	2	74	76	178
01:30 PM	86	6	92	9	2	11	1	93	94	197
01:45 PM	73	12	85	17	2	19	1	91	92	196
Total	320	43	363	48	9	57	4	332	336	756
Grand Total	1317	153	1470	206	34	240	25	1352	1377	3087
Apprch %	89.6	10.4		85.8	14.2		1.8	98.2		
Total %	42.7	5	47.6	6.7	1.1	7.8	0.8	43.8	44.6	
Car	1298	153	1451	205	32	237	22	1337	1359	3047
% Car	98.6	100	98.7	99.5	94.1	98.8	88	98.9	98.7	98.7
Truck	19	0	19	1	2	3	3	15	18	40
% Truck	1.4	0	1.3	0.5	5.9	1.2	12	1.1	1.3	1.3

Massachusetts Department of Transportation

Highway Division

Statewide Traffic Data Collection

File Name : S13-037 6 Gloucester

Site Code : 119308

Start Date : 7/13/2013

Page No : 2

Start Time	Route 127 Washington Street From North			Stanwood Street From East			Route 127 Washington Street From South			Int. Total
	Thru	Left	App. Total	Right	Left	App. Total	Right	Thru	App. Total	
Peak Hour Analysis From 10:00 AM to 01:45 PM - Peak 1 of 1										
Peak Hour for Entire Intersection Begins at 11:30 AM										
11:30 AM	90	22	112	14	3	17	3	98	101	230
11:45 AM	82	8	90	17	3	20	3	73	76	186
12:00 PM	92	7	99	13	1	14	2	93	95	208
12:15 PM	73	11	84	10	0	10	2	100	102	196
Total Volume	337	48	385	54	7	61	10	364	374	820
% App. Total	87.5	12.5		88.5	11.5		2.7	97.3		
PHF	.916	.545	.859	.794	.583	.763	.833	.910	.917	.891

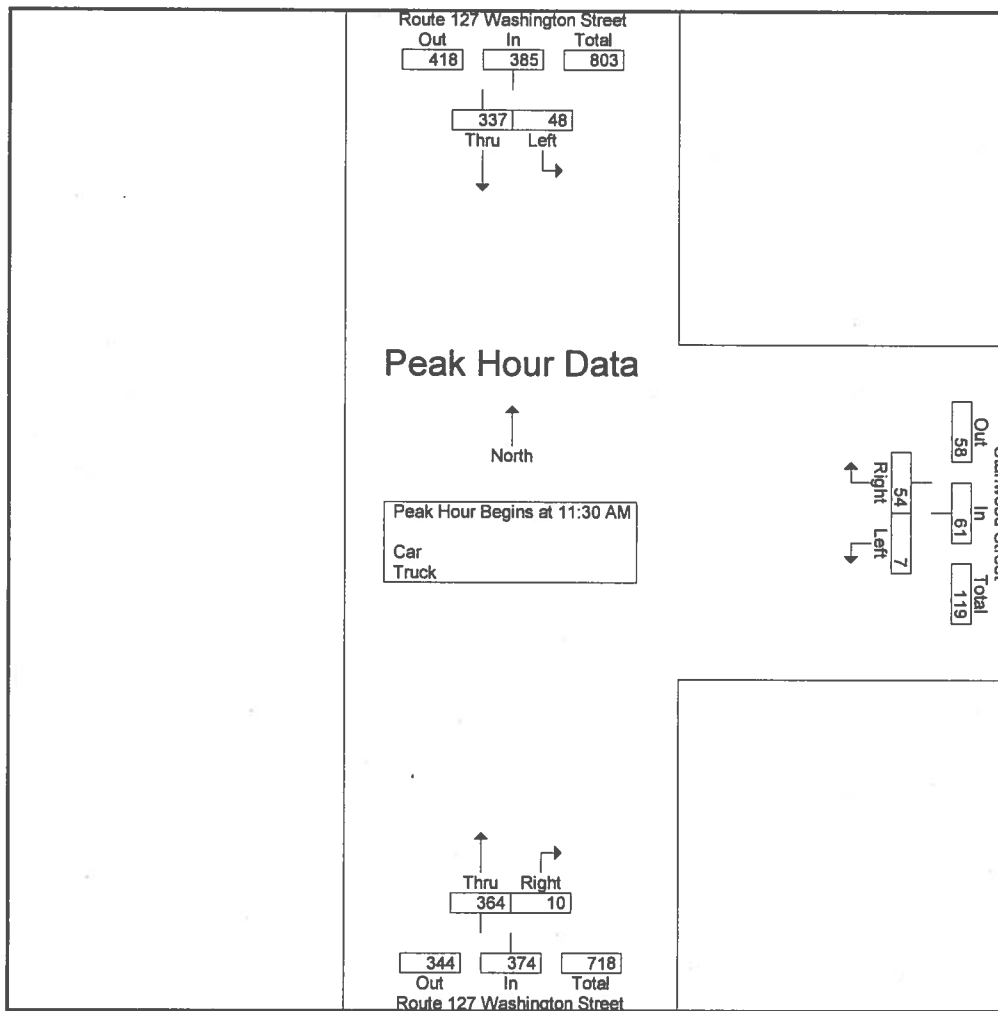

Massachusetts Department of Transportation

Highway Division

Statewide Traffic Data Collection

Gloucester
 Rte 127(Washington St) & Stanwood Street
 Counted by Miovision
 S13-037 TMC # 6

File Name : S13-037 6 Gloucester
 Site Code : 119308
 Start Date : 7/13/2013
 Page No : 1

Groups Printed- Car

Start Time	Route 127 Washington Street From North			Stanwood Street From East			Route 127 Washington Street From South			Int. Total
	Thru	Left	App. Total	Right	Left	App. Total	Right	Thru	App. Total	
10:00 AM	86	13	99	13	0	13	0	65	65	177
10:15 AM	101	14	115	12	2	14	2	73	75	204
10:30 AM	89	8	97	9	5	14	3	60	63	174
10:45 AM	86	3	89	9	3	12	2	85	87	188
Total	362	38	400	43	10	53	7	283	290	743
11:00 AM	87	7	94	14	2	16	0	78	78	188
11:15 AM	73	7	80	14	3	17	1	88	89	186
11:30 AM	89	22	111	14	3	17	3	97	100	228
11:45 AM	81	8	89	17	2	19	3	71	74	182
Total	330	44	374	59	10	69	7	334	341	784
12:00 PM	90	7	97	13	1	14	2	93	95	206
12:15 PM	72	11	83	10	0	10	2	100	102	195
12:30 PM	64	4	68	18	0	18	0	88	88	174
12:45 PM	67	6	73	14	2	16	1	112	113	202
Total	293	28	321	55	3	58	5	393	398	777
01:00 PM	78	13	91	16	2	18	0	74	74	183
01:15 PM	81	12	93	6	3	9	1	72	73	175
01:30 PM	84	6	90	9	2	11	1	93	94	195
01:45 PM	70	12	82	17	2	19	1	88	89	190
Total	313	43	356	48	9	57	3	327	330	743
Grand Total	1298	153	1451	205	32	237	22	1337	1359	3047
Apprch %	89.5	10.5		86.5	13.5		1.6	98.4		
Total %	42.6	5	47.6	6.7	1.1	7.8	0.7	43.9	44.6	

Massachusetts Department of Transportation

Highway Division

Statewide Traffic Data Collection

Gloucester
 Rte 127(Washington St) & Stanwood Street
 Counted by Miovision
 S13-037 TMC # 6

File Name : S13-037 6 Gloucester
 Site Code : 119308
 Start Date : 7/13/2013
 Page No : 1

Groups Printed- Truck

Start Time	Route 127 Washington Street From North			Stanwood Street From East			Route 127 Washington Street From South			Int. Total
	Thru	Left	App. Total	Right	Left	App. Total	Right	Thru	App. Total	
10:00 AM	1	0	1	0	0	0	0	1	1	2
10:15 AM	1	0	1	1	0	1	0	1	1	3
10:30 AM	2	0	2	0	0	0	0	0	0	2
10:45 AM	0	0	0	0	0	0	0	1	1	1
Total	4	0	4	1	0	1	0	3	3	8
11:00 AM	2	0	2	0	0	0	1	3	4	6
11:15 AM	1	0	1	0	0	0	0	0	0	1
11:30 AM	1	0	1	0	0	0	0	1	1	2
11:45 AM	1	0	1	0	1	1	0	2	2	4
Total	5	0	5	0	1	1	1	6	7	13
12:00 PM	2	0	2	0	0	0	0	0	0	2
12:15 PM	1	0	1	0	0	0	0	0	0	1
12:30 PM	0	0	0	0	1	1	1	1	2	3
Total	3	0	3	0	1	1	1	1	2	6
01:00 PM	2	0	2	0	0	0	0	0	0	2
01:15 PM	0	0	0	0	0	0	1	2	3	3
01:30 PM	2	0	2	0	0	0	0	0	0	2
01:45 PM	3	0	3	0	0	0	0	3	3	6
Total	7	0	7	0	0	0	1	5	6	13
Grand Total	19	0	19	1	2	3	3	15	18	40
Apprch %	100	0		33.3	66.7		16.7	83.3		
Total %	47.5	0	47.5	2.5	5	7.5	7.5	37.5	45	

Massachusetts Department of Transportation

Highway Division

Statewide Traffic Data Collection

Gloucester
 Rte 127(Washington St) & Stanwood Street
 Counted by Miovision
 S13-037 TMC # 6

File Name : S13-037 6 Gloucester
 Site Code : 119308
 Start Date : 7/13/2013
 Page No : 1

Groups Printed- Pedal Bike (Road)

Start Time	Route 127 Washington Street From North			Stanwood Street From East			Route 127 Washington Street From South			Int. Total
	Thru	Left	App. Total	Right	Left	App. Total	Right	Thru	App. Total	
10:00 AM	1	0	1	0	0	0	0	1	1	2
10:15 AM	1	2	3	0	0	0	0	0	0	3
10:30 AM	0	0	0	2	0	2	0	1	1	3
10:45 AM	0	0	0	0	0	0	0	1	1	1
Total	2	2	4	2	0	2	0	3	3	9
11:00 AM	8	2	10	1	0	1	0	0	0	11
11:15 AM	2	0	2	0	0	0	0	1	1	3
11:30 AM	15	0	15	0	0	0	0	1	1	16
11:45 AM	0	1	1	0	0	0	0	0	0	1
Total	25	3	28	1	0	1	0	2	2	31
12:00 PM	1	1	2	0	0	0	0	0	0	2
12:15 PM	3	3	6	1	0	1	0	0	0	7
12:30 PM	2	0	2	0	0	0	0	0	0	2
12:45 PM	0	1	1	0	0	0	0	0	0	1
Total	6	5	11	1	0	1	0	0	0	12
01:15 PM	1	0	1	0	0	0	0	0	0	1
01:30 PM	0	1	1	0	0	0	0	1	1	2
01:45 PM	1	0	1	0	0	0	0	0	0	1
Total	2	1	3	0	0	0	0	1	1	4
Grand Total	35	11	46	4	0	4	0	6	6	56
Apprch %	76.1	23.9		100	0		0	100		
Total %	62.5	19.6	82.1	7.1	0	7.1	0	10.7	10.7	

Massachusetts Department of Transportation

Highway Division

Statewide Traffic Data Collection

Gloucester
 Rte 127(Washington St) & Stanwood Street
 Counted by Miovision
 S13-037 TMC # 6

File Name : S13-037 6 Gloucester
 Site Code : 119308
 Start Date : 7/13/2013
 Page No : 1

Groups Printed- Ped

Start Time	Route 127 Washington Street From North		Stanwood Street From East		Route 127 Washington Street From South		Int. Total
	Peds	App. Total	Peds	App. Total	Peds	App. Total	
10:15 AM	0	0	0	0	2	2	2
10:45 AM	0	0	5	5	2	2	7
Total	0	0	5	5	4	4	9
11:00 AM	1	1	0	0	3	3	4
11:15 AM	0	0	0	0	2	2	2
11:30 AM	0	0	0	0	7	7	7
Total	1	1	0	0	12	12	13
12:00 PM	0	0	0	0	1	1	1
12:15 PM	0	0	0	0	2	2	2
12:45 PM	2	2	0	0	1	1	3
Total	2	2	0	0	4	4	6
01:00 PM	0	0	1	1	0	0	1
01:15 PM	2	2	0	0	2	2	4
01:30 PM	0	0	0	0	1	1	1
01:45 PM	0	0	0	0	1	1	1
Total	2	2	1	1	4	4	7
Grand Total	5	5	6	6	24	24	35
Apprch %	100		100		100		
Total %	14.3	14.3	17.1	17.1	68.6	68.6	

APPENDIX I

Summary of Turning Movement Counts by Modes Saturday, July 13, 2013, 10:00 AM – 2:00 PM

Location 1

Rt127A (Thatcher Rd./Bass Ave.) at Atlantic Rd., Gloucester

Location 2

Rt127A (Thatcher Rd.) at Barn Ln., Gloucester

Location 3

Rt127A (Thatcher Rd.) at Witham St., Gloucester

Location 4

Rt127A (Mt. Pleasant St./Broadway) at T-Wharf, Rockport

Location 5

Dock Square (Mt. Pleasant St. at Main St.), Rockport

Location 6

Route 127 (Washington St.) at Stanwood St., Gloucester

Routes 127A/127 Turning Movement Counts by Modes (10:00AM-2:00PM, Saturday, 7/13/2013)

Summary of Peak Hourly Counts by Modes

Locations	Ped Crossings	Bike Counts	Vehicle Counts	Heavy Vehicles	Heavy Veh. %
TMC # 1	40	53	1048	13	1.3%
TMC # 2	4	40	1006	10	1.0%
TMC # 3	24	45	772	6	0.8%
TMC # 4	974	36	899	11	1.4%
TMC # 5	463	36	409	11	2.9%
TMC # 6	13	31	797	13	1.6%

* The peak hourly counts are derived from the highlighted cells in the tables below.

TMC # 1 Rt127A (Thatcher Rd/Bass Ave) at Atlantic Rd, Gloucester

Time	Ped Crossings	Bike Counts	Vehicle Counts	Heavy Vehicles	Heavy Veh. %
10:00-11:00	23	53	899	9	1.0%
11:00-12:00	35	16	1048	10	1.0%
12:00-13:00	21	6	1006	13	1.3%
13:00-14:00	40	20	1037	12	1.2%

TMC # 2 Rt127A (Thatcher Rd) at Barn Ln, Gloucester

Time	Ped Crossings	Bike Counts	Vehicle Counts	Heavy Vehicles	Heavy Veh. %
10:00-11:00	1	40	889	9	1.0%
11:00-12:00	4	14	933	9	1.0%
12:00-13:00	0	6	921	9	1.0%
13:00-14:00	0	22	1006	10	1.0%

TMC # 3 Rt127A (Thatcher Rd) at Witham St, Gloucester

Time	Ped Crossings	Bike Counts	Vehicle Counts	Heavy Vehicles	Heavy Veh. %
10:00-11:00	12	45	686	4	0.6%
11:00-12:00	9	12	689	1	0.1%
12:00-13:00	7	10	699	6	0.9%
13:00-14:00	24	18	772	6	0.8%

TMC # 4 Rt127A (Mt. Pleasant St/Broadway) at T-Wharf, Rockport

Time	Ped Crossings	Bike Counts	Vehicle Counts	Heavy Vehicles	Heavy Veh. %
10:00-11:00	728	36	805	11	1.4%
11:00-12:00	697	17	899	8	0.9%
12:00-13:00	974	21	870	8	0.9%
13:00-14:00	712	10	877	8	0.9%

TMC # 5 Dock Square (Mt. Pleasant St at Main St), Rockport

Time	Ped Crossings	Bike Counts	Vehicle Counts	Heavy Vehicles	Heavy Veh. %
10:00-11:00	136	30	372	3	0.8%
11:00-12:00	285	36	366	5	1.4%
12:00-13:00	362	13	379	11	2.9%
13:00-14:00	463	3	409	8	2.0%

TMC # 6 Route 127 (Washington St) at Stanwood St, Gloucester

Time	Ped Crossings	Bike Counts	Vehicle Counts	Heavy Vehicles	Heavy Veh. %
10:00-11:00	9	9	751	8	1.1%
11:00-12:00	13	31	797	13	1.6%
12:00-13:00	6	12	783	6	0.8%
13:00-14:00	7	4	756	13	1.7%

APPENDIX J

**Pedestrian and Bicycle Counts
Saturday, July 2, 2011
Volunteers of Friends of Gloucester Harbor**

Walker Count
Thatcher Road at Entrance to Good Harbor Beach
Volunteers of Friends of Good Harbor (FOGH)
July 2, 2011 (Saturday)

The following persons served as counters: 8:30-10:30 Don Seccombe
 10:30-12:30 Dolores Mack
 12:30-1:30 Tony Mack
 1:30-3:30 Kathe German & Denton Crews
 3:30-4:30 Kathe German

The following counts were taken:

Period	Cars	M-cycles	B-cycles	Joggers	Walkers	Carriages	Total (W&C)
8:30-9:30			30		6		6
9:30-10:30			22	4	18		18
10:30-11:30	HC	3	29	3	109	2	111
11:30-12:30	HC	11	17	4	51	1	52
12:30-1:30	HC	18	11		79	2	81
1:30-2:30	MC	29	20		106	1	107
2:30-3:30	MC	2	21		56	2	58
3:30-4:30	LC	35	22		99	0	99
*Totals		98	172	11	524	8	532

Key: Cars (HC=Heavy Congestion; MC = Medium Congestion; LC = Light Congestion)

Observations:

1. Between 8:30 and 9:00 over 750 cars traveled the road – traffic was stalled by 9:05 AM.
2. People walking on both sides of road, sometimes three-abreast, one with a ukulele!
3. Paraphernalia (chairs, etc) and baby strollers (sometimes twin) extend into roadway
4. Bicyclists often ride around walkers between cars – including a stretch limo
5. Parking lot full at for non-residents at 9:30 am and residents at 11:30 (usually occurs at 1:00); lot re-opened to residents at 2:30; open to others at 3:30
6. Drop-off area congested; cars sent to Witham for drop-off and Long Beach for parking; some simply drop-off in the street!
7. Trolley drop-off at the boardwalk adds to the congestion on the beach; when the lot is full, the beach is full!
8. On duty: 3 parking lot attendants; 2 patrolmen; supervisor also on-site on day-off
9. Most were on the beach by 3 or so...then the tide reversed...
10. Comments heard: Walker leaving gate - “Here we go again, risking our lives”
 Another walker – “Isn’t there a better way that’s not so dangerous?”
11. People had lots of questions...about parking, availability, other places to park, etc.

Note: *Totals corrected by Stephen Winslow 8/6/2012

APPENDIX K

Comments and Responses

Chen-Yuan Wang

From: Loutzenheiser, David
Sent: Tuesday, February 11, 2014 2:50 PM
To: Chen-Yuan Wang; Stephen Winslow; Joseph Parisi; Bill Steelman; Cleaves, Sam; Raphael, Connie (DOT); mike.karas@state.ma.us; Tim Olson; tdaniel@gloucester-ma.gov; gcademartori@gloucester-ma.gov; peter@capeannchamber.com; jim@easyridertours.com; misrak.sultan@state.ma.us; william.palmer@state.ma.us; jeffrey.cox2@gmail.com; dmenon@salem.com
Cc: Efi Pagitsas; Nelson, Paul (DOT); Scott Peterson; Bourassa, Eric
Subject: RE: Routes 127A/127 (Cape Ann Loop) Study Meeting 2/10/2014 Monday 1:30PM
Attachments: CH_5.pdf

All,

Thank you to CTPS for the presenting their comprehensive analysis and recommendations yesterday in Rockport.

It's clear on the Cape Ann loop that there are very limited opportunities if any to increase the pavement width, so we need to accommodate cyclists (and pedestrians until continuous sidewalks are constructed) in the existing cross section. Therefore we need to consider narrowing the travel lanes as much as feasible to provide proper bicycle accommodation, or alternatively where proper shoulder width is not available (at least 3-4 ft) to stripe the road such that all users of the road share equally the space provided.

I just want to follow up on the lane width discussion. The enclosed chapter of the MassDOT Design Guide provides guidance on lane widths – section 5.3.3.3. 11 ft wide travel lanes are clearly allowed per guidelines, and narrower lanes can be considered via a design exception on urban minor arterials. I believe that 10 ft travel lanes should be considered in some sections.

Furthermore on p 5-32 "In areas of limited ROW, 10 ft lanes can be provided so that the width of the shoulder can be increased to provide greater separation between pedestrians, cyclists, and motor vehicles."

Thanks,

David Loutzenheiser
Transportation Planner
[Bicycle and Pedestrian Program](#)

Online Regional Cycling and Walking Map now Available!
trailmap.mapc.org

[Metropolitan Area Planning Council](#)

60 Temple Place
Boston, MA 02111
617-933-0743



-----Original Message-----

From: Chen-Yuan Wang [<mailto:cwang@ctps.org>]

Sent: Friday, February 07, 2014 4:00 PM

To: Stephen Winslow; Joseph Parisi; Bill Steelman; Cleaves, Sam; Loutzenheiser, David; Raphael, Connie (DOT); mike.karas@state.ma.us; Tim Olson; tdaniel@gloucester-ma.gov; gacademartori@gloucester-ma.gov; peter@capeannchamber.com; jim@easyridertours.com; misrak.sultan@state.ma.us; william.palmer@state.ma.us; jeffrey.cox2@gmail.com; dmenon@salem.com

Cc: Efi Pagitsas; Nelson, Paul (DOT); Scott Peterson

Subject: RE: Routes 127A/127 (Cape Ann Loop) Study Meeting 2/10/2014 Monday 1:30PM

Dear all,

Please be reminded of our final meeting for this study on Monday, 2/10/2014, 1:30PM at Rockport Town Hall. Attached are the agenda and meeting materials for your information. Hope to see you then. Thank you.

Regards, Chen-Yuan Wang

From: Chen-Yuan Wang [<mailto:cwang@ctps.org>]

Sent: Tuesday, January 28, 2014 3:27 PM

Dear Study Advisory members,

Please note the final meeting will be held on 2/10/2014 Monday 1:30PM at the Lower-Lever Conference Room A, Rockport City Hall, 34 Broadway, Rockport. The main purposes of the meeting are to present findings and to discuss the proposed improvements for the study corridor. Hope to see you then.

Regards, Chen-Yuan Wang

Chen-Yuan Wang | Chief Transportation Planner CENTRAL TRANSPORTATION PLANNING STAFF

617.973.8009 | cwang@ctps.org

www.ctps.org/bostonmpo

<< OLE Object: Picture (Device Independent Bitmap) >>

Please be advised that the Massachusetts Secretary of State considers e-mail to be a public record, and therefore subject to the Massachusetts Public Records Law, M.G.L. c. 66 § 10.

Chen-Yuan Wang

From: Loutzenheiser, David
Sent: Wednesday, March 19, 2014 4:57 PM
To: Chen-Yuan Wang; Stephen Winslow; Joseph Parisi; Nelson, Paul (DOT); Bill Steelman; Cleaves, Sam; Raphael, Connie (DOT); mike.karas@state.ma.us; Tim Olson; tdaniel@gloucester-ma.gov; gcademartori@gloucester-ma.gov; barry.pett@masenate.gov; chief@rockportpd.org
Cc: Efi Pagitsas; Bourassa, Eric
Subject: RE: Final Draft Report for Routes 127A/127 (Cape Ann Loop) Study

Thank you Chen-Yuan for providing us the latest draft of this study.

The recommendations for bicycle accommodation still does not address the concerns that I brought up, nor do they reflect the reality of the roadway conditions that limit any widening for much of the corridor. Two foot shoulders are not acceptable bicycle accommodation. Another recommendation needs to be made.

Referring to Figure 8 in the report we do not believe that widening the road to provide shoulder cross sections 1 or 2 are possible on most sections of the roadway due to various physical constraints. The analysis does not address where this may be possible.

Sam and I discussed the draft and offer the following MAPC recommendations for this corridor.

Where 4 foot shoulders are not possible – eliminate the shoulders all together, particularly in sections with sidewalks, and stripe sharrows. Roadway widths are estimated in the 24-28 ft range. Unfortunately the report does not identify existing cross sections at various sample points along the corridor. Elimination of the shoulder consists of either removing the edge line entirely, or moving the edge line to 6 inches from edge of pavement. This allows for clear shared roadway space between bicycle and motor vehicles, as width does not allow for separate accommodation.

Remove the center line and stripe dashed shoulders for pedestrian and bicycle accommodation between Lanesville and Haven Ave (Rockport). A pilot installation of centerline removal and dash shoulders is ideal in this location due to low traffic volumes (< 4000 ADT in the summer, <3000 ADT in winter) and 30mph or less speed limits. A shorter initial section with minimal curves between Lanesville and the Rockport line could be implemented first to evaluate.

Detailed design guidance for such an installation here. Used extensively in Europe, ideal conditions here in Gloucester/Rockport. Plus we can draw on the expertise from Northeastern University that has studied these pavement markings extensively.

<http://sustainabletransportationholland.org/topics/bicycle-advisory-lanes/>

Thanks,

David

From: Chen-Yuan Wang [<mailto:cwang@ctps.org>]
Sent: Friday, March 14, 2014 12:01 PM
To: Stephen Winslow; Joseph Parisi; Nelson, Paul (DOT); Bill Steelman; Cleaves, Sam; Loutzenheiser, David; Raphael, Connie (DOT); mike.karas@state.ma.us; Tim Olson; tdaniel@gloucester-ma.gov; gcademartori@gloucester-ma.gov; barry.pett@masenate.gov; chief@rockportpd.org
Cc: Efi Pagitsas
Subject: Final Draft Report for Routes 127A/127 (Cape Ann Loop) Study

Dear Study Advisory members,

Attached please find a draft of the final report for your review (the appendices is separated from the report due to file size). We hope to get your comments back by next Friday (3/21/2014). We schedule to submit it for MPO approval on 4/17/2014. We apologize for the short notice, as it would take nearly a month to complete the MPO/MassDOT review process. Please note this is a draft not ready for public release until the MPO's approval. Thank you for your helps. Let me know if you have any questions in the documents.

Regards, Chen-Yuan Wang

Chen-Yuan Wang | Chief Transportation Planner

CENTRAL TRANSPORTATION PLANNING STAFF

617.973.8009 | cwang@ctps.org

www.ctps.org/bostonmpo

<<...>> <<...>>

Please be advised that the Massachusetts Secretary of State considers e-mail to be a public record, and therefore subject to the Massachusetts Public Records Law, M.G.L. c. 66 § 10.

Chen-Yuan Wang

From: Raphael, Connie (DOT)
Sent: Monday, February 10, 2014 9:25 AM
To: Chen-Yuan Wang
Subject: RE: Routes 127A/127 (Cape Ann Loop) Study Meeting 2/10/2014 Monday 1:30PM

Hi Chen-Yuan,

I will not be able to attend this afternoon's meeting. I do have a comment on the draft report. MassDOT has a new Engineering Directive regarding design criteria in accordance with the Healthy Transportation Initiative. This directive calls for a minimum of 5 foot shoulders to accommodate bicycles and sidewalks on both sides of the road in urban areas. This applies to all projects on State Highways or funded with State and/or Federal funding. So I would recommend that your proposed cross section include the 5 foot shoulders and two sidewalks where feasible. You may want to consider narrower travel lanes (11 foot).

Connie Raphael
District Four Planning Coordinator
MassDOT - Highway Division

781-641-8468-----Original Message-----

From: Chen-Yuan Wang [<mailto:cwang@ctps.org>]
Sent: Friday, February 07, 2014 4:00 PM
To: Stephen Winslow; Joseph Parisi; Bill Steelman; Cleaves, Sam; Loutzenheiser, David; Raphael, Connie (DOT); Karas, Mike (DOT); Tim Olson; tdaniel@gloucester-ma.gov; gcademartori@gloucester-ma.gov; peter@capeannchamber.com; jim@easyridertours.com; Sultan, Misrak (DOT); Palmer, William (DOT); jeffrey.cox2@gmail.com; dmenon@salem.com
Cc: Efi Pagitsas; Nelson, Paul (DOT); Scott Peterson
Subject: RE: Routes 127A/127 (Cape Ann Loop) Study Meeting 2/10/2014 Monday 1:30PM

Dear all,

Please be reminded of our final meeting for this study on Monday, 2/10/2014, 1:30PM at Rockport Town Hall. Attached are the agenda and meeting materials for your information. Hope to see you then. Thank you.

Regards, Chen-Yuan Wang

From: Chen-Yuan Wang [<mailto:cwang@ctps.org>]
Sent: Tuesday, January 28, 2014 3:27 PM

Dear Study Advisory members,

Please note the final meeting will be held on 2/10/2014 Monday 1:30PM at the Lower-Lever Conference Room A, Rockport City Hall, 34 Broadway, Rockport. The main purposes of the meeting are to present findings and to discuss the proposed improvements for the study corridor. Hope to see you then.

Regards, Chen-Yuan Wang
Chen-Yuan Wang | Chief Transportation Planner CENTRAL TRANSPORTATION PLANNING STAFF
617.973.8009 | cwang@ctps.org
www.ctps.org/bostonmpo

<< OLE Object: Picture (Device Independent Bitmap) >>

Chen-Yuan Wang

From: Raphael, Connie (DOT)
Sent: Monday, March 17, 2014 2:28 PM
To: Chen-Yuan Wang
Cc: Onorato, Joseph (DOT)
Subject: RE: Final Draft Report for Routes 127A/127 (Cape Ann Loop) Study

Hi Chen-Yuan,

I still do not support the one directional bike accommodation. It would be better to narrow the lanes and even the shoulders. I noticed that you mention the need for a waiver. This only applies on State Highway and when the Towns intend to use MassDOT funding. In those cases sidewalks are required on both sides of the roadway and the shoulder width is five feet.

Connie

From: Chen-Yuan Wang [<mailto:cwang@ctps.org>]
Sent: Friday, March 14, 2014 12:01 PM
To: Stephen Winslow; Joseph Parisi; Nelson, Paul (DOT); Bill Steelman; Cleaves, Sam; Loutzenheiser, David; Raphael, Connie (DOT); Karas, Mike (DOT); Tim Olson; tdaniel@gloucester-ma.gov; gacademartori@gloucester-ma.gov; barry.pett@masenate.gov; chief@rockportpd.org
Cc: Efi Pagitsas
Subject: Final Draft Report for Routes 127A/127 (Cape Ann Loop) Study

Dear Study Advisory members,

Attached please find a draft of the final report for your review (the appendices is separated from the report due to file size). We hope to get your comments back by next Friday (3/21/2014). We schedule to submit it for MPO approval on 4/17/2014. We apologize for the short notice, as it would take nearly a month to complete the MPO/MassDOT review process. Please note this is a draft not ready for public release until the MPO's approval. Thank you for your helps. Let me know if you have any questions in the documents.

Regards, Chen-Yuan Wang

Chen-Yuan Wang | Chief Transportation Planner

CENTRAL TRANSPORTATION PLANNING STAFF

617.973.8009 | cwang@ctps.org

www.ctps.org/bostonmpo

<<...>> <<...>>

Chen-Yuan Wang

From: Rabito, Luciano (DOT)
Sent: Friday, March 21, 2014 6:54 AM
To: 'Chen-Yuan Wang'
Subject: RE: Routes 127A/127 Bike Designs

Mr. Wang,

Thank you for reaching out to me regarding your questions on bicycle accommodations. Below are the questions and my responses asked both as part of this email and from our follow up meeting on March 20th at CTPS. Please see my responses below:

- Are wide shoulders (4'-5') on only one side (ocean side) of the roadways in this scenic area acceptable?
Per the Healthy Transportation Policy Directive and Engineering Directive E-14-001 5' is the minimum width for bicycle accommodations.
The attached map shows clearly that there are many sections which transition from bike lanes or usable shoulders to shared use. I would first suggest updating the map to only show bike lanes which measure 5' in width. My guess is this will further reduce the lengths of these sections. I do not see a real benefit to providing accommodations on one side and not the other. In fact I would consider using shared lane and redistributing the width from the bike lane/shoulder more equitably. This is of course based on the assumption that speeds are low (35MPH or less) as are volumes. Narrow travel lanes (<13') generally imply that bicycles should take the lane as there is not enough width for a vehicle to pass a bicycle. Some energy and resources can be directed at other actions such as traffic calming to help reduce speeds and make it more palatable for bicycles to share the road with vehicles.
- Can or should shoulders be completely eliminated on shared travel lanes?
On state highways we stripe a shoulder line as it helps define the edge of travel way. On town roads we typically match existing. In this case assuming it is a state road(s) then I would stripe both shoulders at 2' and take the extra 2-3' and add it to the travel lanes. Note that this may trigger a design exception report for both bicycle accommodation and right shoulder width.
- What is the desirable width for shared road? And a few others.
This is influenced by speed, volumes (both vehicular & bicycle), geometry (horizontal & vertical). The width at which sharrows can be considered is below 16' (this assumes an 11' lane and 5' bike lane/shoulder). From 15' to 13' the placement of the sharrow is 4' from the curb (11' if there is parking). For less than 13' the placement is recommended in the middle of the lane.
- Would it be feasible to not stripe a center line and allow vehicles to pass around bike who would be given a dedicated space?
While this practice has been implemented in other countries it is not an acceptable approach here at this time. Not defining a center line on a roadway that has speeds up to 35MPH and volumes that exceed 10,000 VPD during peak season would not be a recommended action. Wide shared lanes and speed calming techniques would be a viable option to improve safety and comfort for bicycles.
- What is the requirement regarding sidewalks?
The Healthy Transportation Policy Directive issued in September of 2013 has very specific goals and requirements for all MassDOT projects. On all urban roadways we are required to provide two sidewalks for each project. As a way to enforce and monitor this directive MassDOT issued Engineering Directive E-14-001. This directive improved upon our Design Exception process to now include sidewalks and pedestrian

elements. So, any project such as the Route 127A/127 project which fails to meet the two sidewalk requirement and the 5' bike lane/shoulder requirement will need to go through the design exception process. As is the case at this location, sometimes there is just not enough available right of way to meet the needs of all users in the form of separate accommodations for all. The design exception process gives the designer the option to discuss other options which still provide safe and equitable accommodations for all users. Additionally, there are contextual elements that help guide our decision one way or the other.

Thanks,
Lou

Luciano Rabito, P.E.
Complete Streets Engineer
MassDOT
10 Park Plaza
Boston, MA 02116
857.368.9441



Chen-Yuan Wang

From: Chen-Yuan Wang [mailto:cwang@ctps.org]

Sent: Monday, April 07, 2014 2:16 PM

To: 'Bill Steelman'; 'Loutzenheiser, David'; 'Stephen Winslow'; 'Joseph Parisi'; 'Nelson, Paul (DOT)'; 'Cleaves, Sam'; 'Raphael, Connie (DOT)'; 'mike.karas@state.ma.us'; 'Tim Olson'; 'tdaniel@gloucester-ma.gov'; 'gcademartori@gloucester-ma.gov'; 'barry.pett@masenate.gov'; 'chief@rockportpd.org'

Cc: Efi Pagitsas; 'Bourassa, Eric'; 'speterson@ctps.org'; bisler@ctps.org; Luciano.Rabito@state.ma.us

Subject: RE: Final Draft Report for Routes 127A/127 (Cape Ann Loop) Study

Hi Bill,

Thank you for your comments. We also received comments from MAPC and MassDOT, all very helpful; they can be reviewed in the appendix of the memo. We incorporated them all as best as we could; bicycle accommodation is probably the issue that has received the most interest in this study.

Because the major roadways we examined in this study are State numbered routes, they have to follow MassDOT design standards, especially if Federal or State funds are to be used for the improvements. We consulted with MassDOT Complete Streets Engineer and received the following guidance about various design elements which were recommended in comments we received:

- Complete elimination of shoulders: This recommendation could probably only apply to roadways in Downtown Rockport but not on the major sections of Routes 127A/127. On state highways, MassDOT requires the striping of shoulder lines because they help define the edge of travel way, especially at night. In cases of shared road operations for bicycles and vehicles, MassDOT indicated that minimum 1' shoulders are still required.
- Removal of centerlines: Per MassDOT, the removal of centerlines is inappropriate for a corridor such as this due to its speed limit (35 MPH), high traffic volumes, and curved alignments. It would be particularly inappropriate for this specific corridor because:
 - Routes 127 and 127A are minor principal arterials in terms of functional class.
 - The roads are steep and winding in many sections, with frequent horizontal and vertical transitions, where centerlines are essential for safety.
 - Limited selected application in the study corridor would create an inconsistent design and be drastic change from the rest of the corridor, likely causing driver confusion. As such, its application to the limited section near Lanesville would not be appropriate.
 - A major transition section and signing to alert drivers about the change would be required before and after the application section. There no areas in the corridor are sufficient for such transitions.

However, we do think that this no-centerline can be effective in slowing traffic and providing bicycle and pedestrian accommodations in certain situations. In the documentation, we did recommend that elimination of centerlines could be considered for local streets or low-volume collectors in areas adjacent to the study corridor.

I like to stress that this was a study at the conceptual planning stage. Its purpose was to create awareness of the issues and identify potential treatments and a basis from which to spring off to the detailed design stage. We tried to adhere to existing design standards, as presently required by MassDOT. Therefore, at this preliminary planning stage, we can only identify rough sections for shared-road or wide-shoulder applications (as shown in the figures of proposed pedestrian and bicycle accommodations). It is not practical to be specific in terms of locations, as these have to be decided by actual field surveys at the design stage. However, we did try to be inclusive and identify as many potential applications to accommodate pedestrians and bicycles as possible. We discussed all the applications in our report and the comments from MAPC and MassDOT are all included in the report appendices.

Thank you for your help on the study. Chen-Yuan

From: Bill Steelman [<mailto:bills@essexheritage.org>]

Sent: Saturday, April 05, 2014 1:05 PM

To: Loutzenheiser, David; Chen-Yuan Wang; Stephen Winslow; Joseph Parisi; Nelson, Paul (DOT); Cleaves, Sam; Raphael, Connie (DOT); mike.karas@state.ma.us; Tim Olson; daniel@gloucester-ma.gov; gcademartori@gloucester-ma.gov; barry.pett@masenate.gov; chief@rockportpd.org

Cc: Efi Pagitsas; Bourassa, Eric

Subject: RE: Final Draft Report for Routes 127A/127 (Cape Ann Loop) Study

Chen-Yuan:

Could I kindly ask that you reply/respond to the issues raised in the email below, particularly as they relate to MAPC's recommendations?

I know the clock is ticking but, after some consideration, I do believe that it is in the future best interests of all roadway users (cyclists, pedestrians and motorists) that the study to be as location focused and specific as it can be in its recommendations. Any monies that may be available for improvements will only likely be accessed for solutions that address the safety of the non-vehicular users. Without the promise of meaningful advancements in safety vis-a-vis the recommendations I think what is now a challenging funding request will become an impossible one.

While not the engineer in the group, it does seem to me that it is possible to implement the shoulder recommendations on certain specific sections of the route. It is those possibilities that I believe warrant further attention and consideration.

Thank you for your efforts on behalf of our region.

Regards,

Bill Steelman
Essex Heritage
(978) 740-0444

From: Loutzenheiser, David [<mailto:DLoutzenheiser@mapc.org>]

Sent: Wednesday, March 19, 2014 4:57 PM

To: Chen-Yuan Wang; Stephen Winslow; Joseph Parisi; Nelson, Paul (DOT); Bill Steelman; Cleaves, Sam; Raphael, Connie (DOT); mike.karas@state.ma.us; Tim Olson; daniel@gloucester-ma.gov; gcademartori@gloucester-ma.gov; barry.pett@masenate.gov; chief@rockportpd.org

Cc: Efi Pagitsas; Bourassa, Eric

Subject: RE: Final Draft Report for Routes 127A/127 (Cape Ann Loop) Study

Thank you Chen-Yuan for providing us the latest draft of this study.

The recommendations for bicycle accommodation still does not address the concerns that I brought up, nor do they reflect the reality of the roadway conditions that limit any widening for much of the corridor. Two foot shoulders are not acceptable bicycle accommodation. Another recommendation needs to be made.

Referring to Figure 8 in the report we do not believe that widening the road to provide shoulder cross sections 1 or 2 are possible on most sections of the roadway due to various physical constraints. The analysis does not address where this may be possible.

Sam and I discussed the draft and offer the following MAPC recommendations for this corridor.

Where 4 foot shoulders are not possible – eliminate the shoulders all together, particularly in sections with sidewalks, and stripe sharrows. Roadway widths are estimated in the 24-28 ft range. Unfortunately the report does not identify existing cross sections at various sample points along the corridor. Elimination of the shoulder consists of either removing the edge line entirely, or moving the edge line to 6 inches from edge of pavement. This allows for clear shared roadway space between bicycle and motor vehicles, as width does not allow for separate accommodation.

Remove the center line and stripe dashed shoulders for pedestrian and bicycle accommodation between Lanesville and Haven Ave (Rockport). A pilot installation of centerline removal and dash shoulders is ideal in this location due to low traffic volumes (< 4000 ADT in the summer, <3000 ADT in winter) and 30mph or less speed limits. A shorter initial section with minimal curves between Lanesville and the Rockport line could be implemented first to evaluate.

Detailed design guidance for such an installation here. Used extensively in Europe, ideal conditions here in Gloucester/Rockport. Plus we can draw on the expertise from Northeastern University that has studied these pavement markings extensively.

<http://sustainabletransportationholland.org/topics/bicycle-advisory-lanes/>

Thanks,

David

From: Chen-Yuan Wang [mailto:cwang@ctps.org]

Sent: Friday, March 14, 2014 12:01 PM

To: Stephen Winslow; Joseph Parisi; Nelson, Paul (DOT); Bill Steelman; Cleaves, Sam; Loutzenheiser, David; Raphael, Connie (DOT); mike.karas@state.ma.us; Tim Olson; tdaniel@gloucester-ma.gov; gcademartori@gloucester-ma.gov; barry.pett@masenate.gov; chief@rockportpd.org

Cc: Efi Pagitsas

Subject: Final Draft Report for Routes 127A/127 (Cape Ann Loop) Study

Dear Study Advisory members,

Attached please find a draft of the final report for your review (the appendices is separated from the report due to file size). We hope to get your comments back by next Friday (3/21/2014). We schedule to submit it for MPO approval on 4/17/2014. We apologize for the short notice, as it would take nearly a month to complete the MPO/MassDOT review process. Please note this is a draft not ready for public release until the MPO's approval. Thank you for your helps. Let me know if you have any questions in the documents.

Regards, Chen-Yuan Wang

Chen-Yuan Wang | Chief Transportation Planner

CENTRAL TRANSPORTATION PLANNING STAFF

617.973.8009 | cwang@ctps.org

APPENDIX L

Roadway Design: Bicycle Advisory Lanes Sustainable Transportation in the Netherlands

Sustainable Transportation in the Netherlands

A website Created by Peter Furth and students of Northeastern University

Bicycle Advisory Lanes

Written by Peter Ellison and William Gray, Contributions by Tomas Bertulis (2011)

Updated by Ayan Majmudar, Andrew Raffo, and Bea van den Heuvel (2012)

Updated by Andrew Brunn and Joel Shaffer (2013)

Many two-way roads are too narrow to simultaneously allow two lanes of traffic to travel and also allow two bicycles to travel. The solution in the Netherlands has been to install shared bicycle lanes on these roads called advisory lanes or suggestion lanes. Advisory lanes are created in areas where separate cycle tracks cannot be made, whether from spatial or government restrictions. The CROW manual only refers to advisory bike lanes and legal bike lanes whereas it does not mention shared bicycle lanes. A shared bicycle lane is a term that can be used to describe both legal bicycle lanes as well as advisory bicycle lanes.

Installing shared bicycle lanes versus unshared bicycle lanes on a road depends on the road's width. If a road is wide enough to accommodate two lanes for motor vehicle travel and two lanes for bicycle travel, then unshared bicycle lanes will be installed since all traffic has enough road width to safely pass. If a road is too narrow to accommodate two lanes for motor vehicle travel along with two lanes for bicycles, then shared bicycle lanes may be installed. These lanes make it possible for cars traveling in opposing direction to pass one another by allowing them to use the shared bicycle lanes as the extra room they need to pass. Normally installing shared lanes means no centerline will be installed, yet still designate sufficient space for bikes. The 1998 Dutch CROW ASVV: Recommendations for Traffic Provisions in Built-up Areas, recommends centerlines only in situations where crossing the centerline will result in great risk such as on heavily traveled roads with high speeds. In contrast, the Manual on Uniform Traffic Control Devices in the United States states that a centerline is needed for urban roads with average daily traffic (ADT) above 6,000 vehicles per day and for rural roads with average daily traffic above 3,000 vehicles per day.



Typical Shared Bicycle Lanes- Pauwstraat in Delft

Intended Use

Advisory lanes suggest where vehicles and cyclists should operate given the confined width of a narrow street. Bicyclists are advised to travel in the designated shoulders of the road and motorists are advised to drive in the designated center (which is too narrow for two-way vehicular traffic). Therefore, motorists can easily pass cyclists when they encounter one another. When two vehicles traveling in opposing directions encounter one another, they can temporarily move into the advised cycling lanes to avoid a conflict. This reasoning can be used for a variety of potential conflicts involving personal vehicles, buses, mopeds, and bicycles traveling in the same or opposite directions.

Designed Use

The basic setup for advisory lanes is a road for motorized vehicles sandwiched between two bicycle lanes with dashed lines. Advisory lanes do not have any centerlines and therefore leaves passing and decision making up to the cyclists and vehicle operators. These lanes ensure the best use of the entire width of the road by directing cars down the center of the road and allowing lanes of bicycles to pass on either side. When two cars traveling in opposing directions meet, they yield to passing bicyclists and then utilize the shared bicycle lanes to perform their pass. In the Netherlands, roads with shared bicycle lanes are usually collector roads that collect the traffic from small local roads and direct it to a main road. They normally do not have a centerline and mainly have low to moderate volume traffic traveling at speeds of 30 – 50 km/hr in urban areas and up to 60 km/hr in rural areas. These lanes make safe bike and vehicle travel possible on narrow roads.

Actual Use

The Netherlands mainly utilizes shared bicycle lanes on narrow urban and rural collector roads with low to moderate traffic to allow roads to remain two-way and still provide bicycles with a safe lane of travel. Cars respect the shared bicycle lane in the same manner as an unshared bicycle lane and when attempting to pass one another give priority to any traveling bicycles and yield before completing their pass. The consistent speed of bicycle travel in the shared bicycle lane means that cars passing each other do not have to wait very long at all when yielding to a bicycle before entering the shared lane. The existence of these lanes creates a sort of etiquette on the road where both the car driver and bicyclist knows where each should be and how to efficiently share the road should an instance of passing occur. Also, these lanes cause an expectation to be created where car drivers are aware that bicycles may be traveling in this nearby marked lane.



Bicycle and Car traveling in advised areas on S. V. D. Oyeweg in Pijnacker



Car yielding to traveling bicycles by utilizing shared bicycle lane on the Westplantsoen in Delft



Car shows recognition of bicycles by moving over into shared bicycle lane on the Molenweg in Nootdorp.



Cars utilizing full road width to pass on the Zuideindseweg in Delfgauw

APPENDIX M

**MassDOT Engineering Directive (Interim) E-14-001
February 4, 2014**

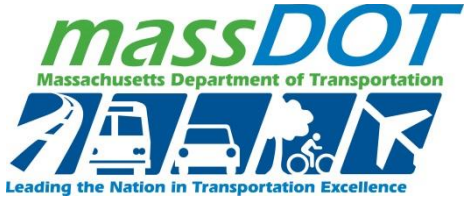

Policy: P-13-0001

Date: September 9, 2013

HEALTHY TRANSPORTATION POLICY DIRECTIVE

Secretary of Transportation and Chief Executive Officer

Highway Division Administrator

MBTA General Manager and Rail and Transit Administrator

Aeronautics Division Administrator

Executive Director, Office of Transportation Planning

I. Healthy Transportation Policy Directive:

This directive formalizes MassDOT's commitment to the implementation and maintenance of transportation networks that serve all mode choices for our customers and that was memorialized in our Mode Shift Goal announced October 2012.

II. Goal:

To further MassDOT's GreenDOT Implementation Plan, the Commonwealth's Healthy Transportation Compact and statewide Mode Shift Goal, this *Healthy Transportation Policy Directive* is issued to ensure all MassDOT projects are designed and implemented in a way that all our customers have access to safe and comfortable healthy transportation options at all MassDOT facilities and in all the services we provide. This directive builds on other existing directives and guidance that addresses such issues. Healthy Transportation modes as defined by GreenDOT are walking, bicycling and taking transit.

III. Implementation:

1) Project Reviews

In order to ensure that healthy transportation modes are considered equally as potential solutions within project design, this *Healthy Transportation Policy Directive* requires the following:

- 1A. All MassDOT funded and or designed projects shall seek to increase and encourage more pedestrian, bicycle and transit trips. MassDOT has established a statewide mode shift goal that seeks to triple the distance traveled by walking, bicycling and transit by 2030, promoting intermodal access to the maximum extent feasible will help the agency meet this goal.

- 1B. The MassDOT Highway, Rail & Transit, and Aeronautics Divisions shall undertake a review process to evaluate all projects currently under MassDOT design oversight for conformance with the specifications and spirit of this *Healthy Transportation Policy Directive*. This process must be completed by January 1, 2014 and submitted to the Secretary and CEO for review. Projects programmed for federal and state funding within the next four fiscal years should be reviewed as a priority. For projects under the Highway Division, the emphasis should be on those projects that entered the design review process before the adoption of the *2006 Project Development and Design Guide*. Projects should not advance in the design process until they have undertaken this review.

- 1C. MassDOT funded and or designed projects that fail to provide facilities for healthy transportation modes, as identified by the aforementioned reviews, shall require signoff by the Secretary and CEO of Transportation prior advancing additional design work. For the Highway Division, this shall not apply to roadway facilities that already prohibit bicyclists and pedestrians, such as limited access highways, or Interstates.

- 1D. Projects under contract for construction, currently under bid review, or advertised for construction on the date of this policy adoption, do not need to undergo major modifications. However, each MassDOT Division shall submit a list of these projects to the Secretary and CEO of Transportation by October 1, 2013 highlighting healthy transportation design opportunities.

- 1E. MassDOT construction projects shall include provisions of off-road accommodations (shared use path, or bridge side path) or clearly designate safe travel routes for pedestrians, bicyclists, and transit users along existing facilities, including customers that fall under the protection of the Americans with Disabilities Act.

2) Project Design Process

- 2A. All design notices and public communications for projects shall clearly state the following: 1) existing walking, bicycling and transit facilities/routes that are within the project site area to educate the community on their options for attending public meetings or hearings, and 2) walking, bicycling and transit facilities/routes that are within the project site area that are proposed in the project.

- 2B. All proposed project scopes of work and associated budgets being prepared by the Highway Division shall clearly detail walking (along with identified deficiencies in ADA compliance), bicycling and transit facilities/routes that are within the project site area at the time of project number issuance. In addition, existing or proposed networks within a 2-mile radius of the proposed project, critical connections to downtowns or transit facilities, and all Bay State Greenway routes shall be clearly identified.
- 2C. All MassDOT facilities shall be responsive to adjacent land uses and site context. Wherever adjacent land uses include commercial development or residential development of greater than five units per acre, a sidewalk should be provided along the roadway adjacent to the use. The potential for walking, bicycling and transit activity increases due to existing or planned land uses such as: schools, public parks and playgrounds, hospitals, retail centers, senior centers or housing, multi-family housing, or community centers. Design features to consider shall include, but not limited to: wider sidewalks, street trees, landscaped buffers, benches, lighting, frequent crossing opportunities and strong intermodal connectivity to transit. All project proposals being reviewed or designed by MassDOT shall provide a project site context map with basic information about the site location, and land use (commercial, office, institutional, educational, etc.).
- 2D. MassDOT shall initiate road safety audits of known clustered incident sites where healthy transportation users are involved, to improve customer safety for more vulnerable users. This effort shall have an initial emphasis on healthy transportation users in Environmental Justice communities. By December 31, 2014 the Highway Division shall identify and conduct road safety audits for all high crash location clusters for healthy transportation users along MassDOT owned facilities where that cluster falls in areas where two of three, or all Environmental Justice community thresholds are exceeded (low-income, minority or limited English proficiency). By June 30, 2015 the Highway Division shall have developed a process to implement safety projects to address the locations identified. This process shall include the development of metrics for success and identify a reasonable completion date.
- 2E. For projects along non-limited access rights-of-way in urbanized areas, sidewalks shall be provided on both sides of roadway rights-of-way with added attention to ADA compliance. Every bridge, overpass or underpass shall provide sidewalks on both sides of the road, even if comparable facilities do not yet exist on the abutting road segments, unless pedestrian travel is already prohibited along the roadway.
- 2F. All project proposals being reviewed or designed by MassDOT including new design, retrofits and maintenance shall not remove existing pedestrian or bicycle facilities unless those are replaced by facilities providing equal or better Level of Service. They shall also seek to add facilities that increase and encourage healthy transportation for pavement restoration and resurfacing projects including opportunities to meet ADA compliance. These plans shall be signed off on by the District Highway Engineer and electronic copies provided to the Office of Transportation Planning.
- 2G. The MassDOT Highway and Rail & Transit Divisions shall establish a guide for use by communities that propose Shared Use Paths on or along rail beds. The guide shall be written to assist communities in understanding the design standards (including ADA compliance) for such paths, especially along active rail lines, and acquiring rights of way with the intention of accelerating the design of Shared Use Paths, especially those facilities that are an element of the Bay State Greenway and/or provide critical connections to downtowns or transit facilities. The MassDOT Highway and Rail & Transit Divisions shall permit Shared-Use Paths to be installed along active or future railroad rights-of-way (Rails with Trails) provided appropriate fencing separates the two uses.

2H. For the design of bicycle facilities MassDOT shall consider, but not be limited to, the *AASHTO Guide for the Development of Bicycle Facilities* (2012) and the *NACTO Urban Bikeway Design Guide* (2012) as supplements to the *Project Development and Design Guide* (2006), except for pavement markings not approved by MUTCD. MassDOT should utilize other guides as they emerge and evolve from NACTO, AASHTO, and/or the US Department of Transportation.

2I. For the design of bus stop facilities MassDOT shall consider, but not be limited to, guidelines of the MBTA Bus Stop Planning and Design Guide (2013) and guidance on ADA compliance. MassDOT should utilize other guides as they emerge and evolve from NACTO, AASHTO, and/or the US Department of Transportation.

2J. Upon completion of all healthy transportation facilities, the location, description, and length must be submitted to the appropriate MassDOT offices to facilitate asset management activities.

Please Post _____

Do Not Post _____

APPENDIX N

List of Intersections with Relatively Wide Layouts

List of Intersections with Relatively Wide Layouts in the Study Corridor

Intersections on Route 127A:

- Bass Ave at Sayward Street/Brightside Avenue, Gloucester
- Bass Ave at Atlantic Road, Gloucester
- Thatcher Road at Witham Street, Gloucester
- Thatcher Road at Rockport Road, Gloucester
- Thatcher Road at South Street, Rockport
- Mount Pleasant Street at Atlantic Avenue, Rockport
- Mount Pleasant Street at Broadway, Rockport

Intersections on Route 127:

- Main Street/Railroad Avenue at Broadway/Parker Street (Five-Corner), Rockport
- Railroad Avenue/Granite Street at King Street/Summit Avenue, Rockport
- Granite Street at Beach Street, Rockport
- Granite Street at Wharf Road, Rockport
- Granite Street at Beach Street, Rockport
- Granite Street at Curtis Street (south segment) , Rockport
- Granite Street at Curtis Street (north segment) , Rockport
- Granite Street at Gott Avenue, Rockport
- Granite Street at Bay View Avenue, Rockport
- Washington Street at Langsford Street, Gloucester
- Langsford Street at Andrews Street, Gloucester
- Langsford Street at Washington Street, Gloucester
- Washington Street at Duley Street, Gloucester
- Washington Street at Brierwood Street, Gloucester
- Washington Street at Holly Street, Gloucester
- Washington Street at Reynard Street, Gloucester
- Washington Street at Hodgkins Street, Gloucester

Intersections in Downtown Rockport:

- Mount Pleasant Street at Main Street (Dock Square)
- Main Street at Beach Street